



HAL
open science

Where the Risks Lie: A Survey on Systemic Risk

Sylvain Benoît, Jean-Edouard Colliard, Christophe Hurlin, Christophe Pérignon

► **To cite this version:**

Sylvain Benoît, Jean-Edouard Colliard, Christophe Hurlin, Christophe Pérignon. Where the Risks Lie: A Survey on Systemic Risk. 2015. halshs-01142014v2

HAL Id: halshs-01142014

<https://shs.hal.science/halshs-01142014v2>

Preprint submitted on 21 Dec 2015

HAL is a multi-disciplinary open access archive for the deposit and dissemination of scientific research documents, whether they are published or not. The documents may come from teaching and research institutions in France or abroad, or from public or private research centers.

L'archive ouverte pluridisciplinaire **HAL**, est destinée au dépôt et à la diffusion de documents scientifiques de niveau recherche, publiés ou non, émanant des établissements d'enseignement et de recherche français ou étrangers, des laboratoires publics ou privés.

Where the Risks Lie: A Survey on Systemic Risk*

Sylvain Benoit[†] Jean-Edouard Colliard[‡] Christophe Hurlin[§] Christophe Pérignon[¶]

November 13, 2015

Abstract

We review the extensive literature on systemic risk and connect it to the current regulatory debate. While we take stock of the achievements of this rapidly growing field, we identify a gap between two main approaches. The first one studies different sources of systemic risk in isolation, uses confidential data, and inspires targeted but complex regulatory tools. The second approach uses market data to produce global measures which are not directly connected to any particular theory, but could support a more efficient regulation. Bridging this gap will require encompassing theoretical models and improved data disclosure.

Keywords: Banking, Macroprudential Regulation, Systemically Important Financial Institutions, Financial Crises, Too-Big-To-Fail.

JEL classification: G01, G32.

*We are grateful to Franklin Allen (the editor), an anonymous referee, Tobias Adrian, Olivier De Bandt, Thierry Foucault, Peter Feldhutter, Christian Gourieroux, Lasse Pedersen, Olivier Scaillet, David Thesmar, Guillaume Vuilleme, seminar participants at Paris Dauphine and participants at the New Frontiers in Systemic Risk Measures and Extreme Risk Management Conference (New York) and the SYRTO Conference on Systemic Risk (Amsterdam) for their comments and suggestions. We would like to warmly thank Steven Ongena for encouraging us to write this survey. Financial support from the Chair ACPR/Risk Foundation: Regulation and Systemic Risk is gratefully acknowledged.

[†]University of Paris-Dauphine, France. E-mail: sylvain.benoit@dauphine.fr

[‡]HEC Paris, France. E-mail: colliard@hec.fr

[§]University of Orléans, France. E-mail: christophe.hurlin@univ-orleans.fr

[¶]HEC Paris, France. E-mail: perignon@hec.fr

1 Introduction

Systemic risk is often seen as a “hard-to-define-but-you-know-it-when-you-see-it” concept. However, research has long developed a theoretical corpus to identify the main mechanisms behind systemic risk, starting with e.g. [Bernanke and Gertler \(1989\)](#), [Rochet and Tirole \(1996a\)](#), [Allen and Gale \(2000b\)](#), and [Acharya \(2001\)](#). More recently, the need for answers to pressing regulatory problems triggered a surge in the applied literature on systemic risk. Systemic risk has become a prolific research field at the crossroads of banking, macroeconomics, econometrics, network theory, etc.

Today, systemic risk is a particularly good example of a field in which academic research and financial regulation cross-fertilize, with the ultimate goal of better identifying the vulnerabilities of the financial system. Ideally, regulators need measures of systemic risk that are timely, capture well-identified economic mechanisms, and can be used as an input for regulatory tools. Keeping these objectives in mind, we survey the literature on systemic risk with the aim of discussing the mapping between theories, empirical measures, and regulatory reforms (see [Table 1](#) for a preview). We also highlight potential gaps in this mapping and discuss the regulatory shortcomings they could lead to. The papers we review follow two distinct approaches:

A first strand of the literature looks at specific sources of systemic risk, such as contagion, bank runs, or liquidity crises. This “source-specific approach” relies on several families of qualitative models, which deliver predictions that can be confirmed by empirical analyses, often based on supervisory data. In line with this literature, a variety of tools have been introduced to monitor the many different channels of systemic risk and realign banks’ behavior with financial stability. While the regulatory community had long called for such “macroprudential” tools ([Crockett \(2000\)](#), [Borio \(2003\)](#)), it is only recently that academics started analyzing them (see e.g. [Hanson, Kashyap, and Stein \(2011\)](#)).

Table 1: Synoptic Table.

This table matches each source of systemic risk identified in the survey (Column 1) with representative theory papers (Column 2), empirical papers that either provide evidence supporting the associated economic mechanism or propose a corresponding risk measure (Column 3), regulatory tools (Column 4), and empirical evaluations of these tools (Column 5).

	Theory	Evidence/Measure	Regulation	Policy Evaluation
I. Source-Specific Approach				
Systemic risk-taking				
Correlation risk	Acharya (2001) Farhi and Tirole (2012)	Lehar (2005) Blei and Ergashev (2014)	Sectoral capital requirements Loan-to-value ratios	Ono <i>et al.</i> (2013)
Liquidity risk	Bhattacharya and Gale (1987) Brunnermeier and Oehmke (2013b)	Brunnermeier, Gorton, and Krishnamurthy (2014) Jobst (2014)	Liquidity Coverage Ratio Net Stable Funding Ratio	Banerjee and Mio (2014)
Tail risk	Perotti, Ratnovski, and Vlahu (2011) Freixas and Rochet (2013)		Stress-tests	-
Leverage cycles	Bernanke and Gertler (1989) Kiyotaki and Moore (1997)	De Nicoló and Lucchetta (2011) He and Krishnamurthy (2014)	Countercyclical buffers	Aiyar, Calomiris, and Wieladek (2014) Jimenez <i>et al.</i> (2014)
Contagion				
Balance-sheet contagion	Allen and Gale (2000b) Freixas, Parigi, and Rochet (2000)	Elsinger, Lehar, and Summer (2006) Drehmann and Tarashev (2011)	Large exposure limits Resolution framework	-
Payment and clearing infrastructures	Rochet and Tirole (1996a) Freixas and Parigi (1998) Duffie and Zhu (2011)	McAndrews and Potter (2002)	Mandatory clearing	Duffie, Scheicher, and Vuillemeij (2015)
Informational contagion	Chen (1999) Dasgupta (2004)	Calomiris and Mason (1997) Bae, Karolyi, and Stulz (2003)	Stress-test disclosure	Petrella and Resti (2013) Ellahie (2013)
Amplification				
Liquidity crises	Shleifer and Vishny (1992) Brunnermeier and Pedersen (2009)	Greenwood, Landier, and Thesmar (2015) Duarte and Eisenbach (2015)	Lending of last resort	-
Market freezes	Flannery (1996) Heider, Hoerova, and Holthausen (2015)	Afonso, Kovner, and Schoar (2011) Acharya and Merrouche (2013)	Stress-test disclosure Additional supervision	Petrella and Resti (2013) Ellahie (2013)
Runs	Diamond and Dybvig (1983) Calomiris and Kahn (1991) Martin, Skeie, and Von Thadden (2014)	Chen, Goldstein, and Jiang (2010) Iyer and Peydró (2011) Iyer and Puri (2012)	Extended deposit insurance Bail-outs	-
II. Global Approach				
	-	Acharya <i>et al.</i> (2010) Billio <i>et al.</i> (2012) Adrian and Brunnermeier (2014) Brownlees and Engle (2015)	Capital surcharge for SIFIs	Moeninghoff, Ongena, and Wieandt (2015)

A second family of papers aims to derive global measures of systemic risk, potentially encompassing all the mechanisms studied in the first group of papers. Particularly popular examples include the SRISK and the ΔCoVaR . While this “global approach” is more statistical in nature and does not take a particular stand on the causes of systemic risk, it could provide tools to replace a host of complex macroprudential tools by a simple Pigovian “systemic risk tax” that would restore an optimal level of risk-taking.

While both approaches have merits, we call for more integration between them. The availability of new macroprudential tools makes it pressing to understand how they interact with each other, which implies going beyond the study of different sources of systemic risk in isolation. Conversely, it may appear hazardous to base regulation on global statistical measures without a clear understanding of the risks they capture and the ones they overlook. In particular, we provide evidence that some popular measures may not be sufficient metrics of systemic risk, as they seem to a great extent driven by market risk.

In order to encompass the literature in all its richness and diversity, we adopt a minimal definition of systemic risk. We define it as the risk that many market participants are simultaneously affected by severe losses, which then spread through the system. This definition can apply to a huge number of papers, of which we survey 220, published over the past 35 years. In order to uncover the fundamental structure of this research area, we display all the cited papers as a network in Figure 1.

In our survey, we group papers by source of systemic risk. A first strand of papers explain *systemic risk-taking*, or why many financial institutions take bets that are both large and correlated. Second, there is a rich literature on *contagion* mechanisms, or how losses can spillover from one part of the financial system to another. Third, we discuss *amplification* mechanisms, or why small shocks can end up having large impacts. This classification is heuristic and meant for presentation purposes, as several papers can belong to more than one category.

In Figure 1, we color the nodes corresponding to the thirty most cited papers in our sample according to where they appear in the survey. The systemic risk-taking/contagion/amplification structure, which forms the backbone of this survey, appears to be well supported by the citation data. In particular, there are five papers on systemic risk-taking (in blue), a cluster on contagion mechanisms (in green), and a group of papers on amplification mechanisms (in

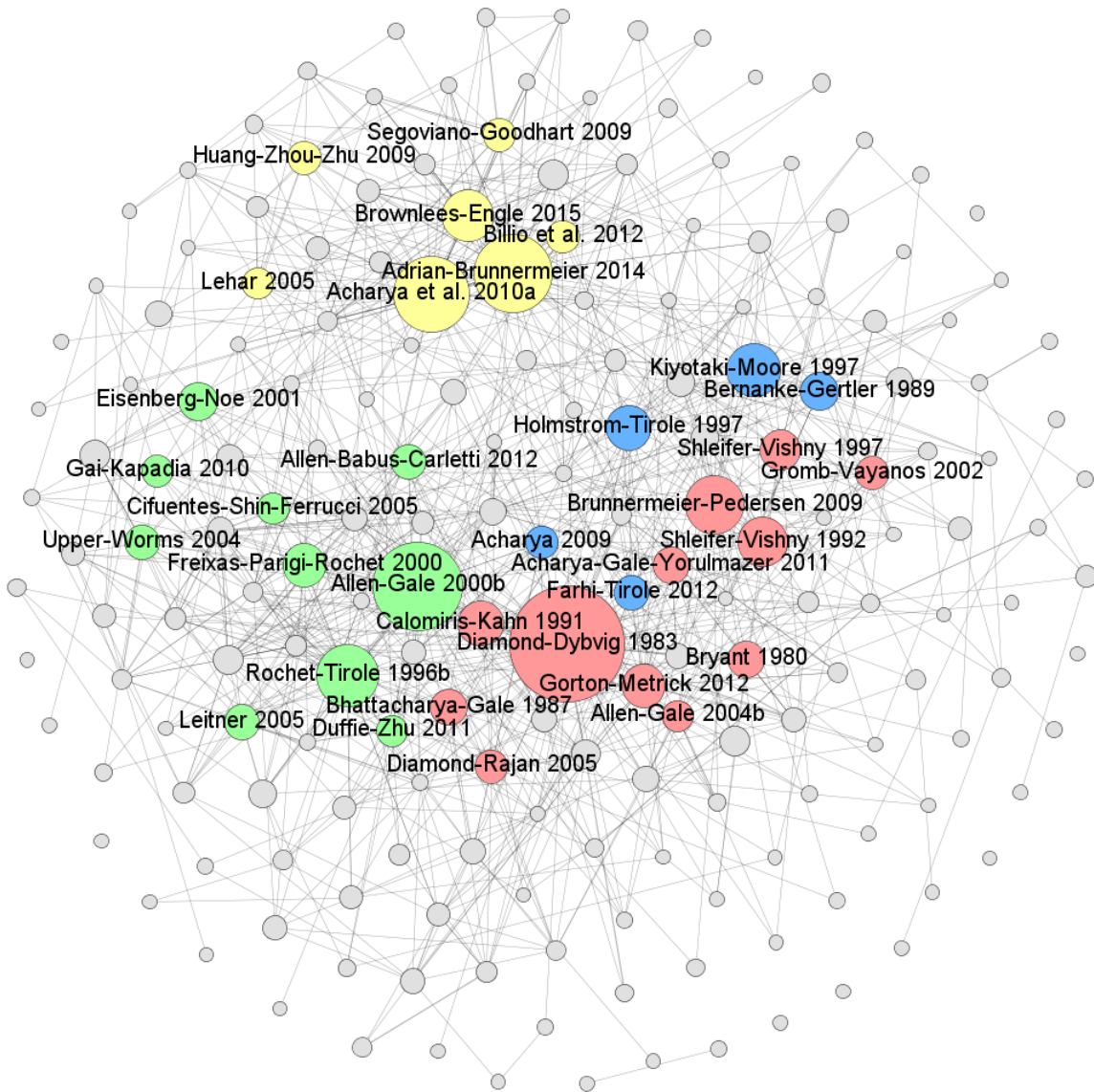

Figure 1: Systemically important articles and their periphery. This network diagram displays a graph of the 220 articles reviewed in the present survey. The size of each circle is proportional to the number of times each article is cited by other articles in the survey, whereas the edges represent citations. The position of nodes is based on the Fruchterman-Reingold algorithm. As a result, papers with many cross-citations appear as clusters in the graph. We display the names of the authors of the 34 papers that are cited the most in our sample and color them according to the strand of the literature they belong to: systemic risk-taking (blue), amplification mechanisms (red), contagion (green), and systemic risk measures (yellow). Surveys and policy papers are excluded from the network.

red). The last cluster (in yellow) consists of papers on systemic risk measurement and seems more loosely connected to the rest of the literature, although this can be partly explained by these papers being more recent.

The outline of our survey is as follows. We start by reviewing the different theories explaining the sources of systemic risk in Section 2. We organize these theoretical papers using our classification: systemic risk-taking, contagion, and amplification mechanisms. We then study in Section 3 the tools that regulators and academics have proposed to address the vulnerabilities identified in Section 2. While we acknowledge the progress made by regulation since the beginning of the financial crisis, we also point towards gaps between regulatory and academic proposals, and potential challenges that will need to be addressed in the future.

Efficient regulation needs to rely on a sound quantification of systemic risk. Measures specific to a particular risk channel are useful to calibrate the targeted macroprudential tools discussed in Section 3. Alternatively, global measures aiming at quantifying the total systemic risk contribution of a financial institution are necessary to identify the systemically important financial institutions (SIFIs) and subject them to higher capital requirements or a systemic risk tax. After discussing the shortcomings of the current methodology used by the Basel Committee on Banking Supervision (BCBS) to identify SIFIs, we review both types of measures in Section 4.

Given the number of measures proposed in the literature, regulators need ways to compare them and choose the ones most suited to their needs. We contribute to this objective by deriving some of the most popular global measures of systemic risk in a unified framework in Section 5, and show that these measures are strongly related to standard market risk measures such as market beta and Value-at-Risk (VaR). This finding suggests that additional measures are required to capture other facets of systemic risk. We then review the various methods that have been suggested to evaluate and compare systemic risk measures in Section 6.

Our survey can be of interest to several audiences. We aim to propose to academics working in the field a broad perspective that identifies how the different parts of the literature build a consistent body of knowledge, with some gaps to be filled by later studies. Regulators and policymakers should find an overview of the literature pointing out various rationales for existing regulations, proposals for new tools, and ready-to-use methodologies that could be implemented for measuring and regulating systemic risk. Finally, students may find in this

survey a welcoming point of entry into a vast and daunting literature.

While we try to be as comprehensive as possible in this survey, this is necessarily at the cost of not doing full justice to any particular line of research. For instance, researchers working on bank runs, interbank networks or macro-finance may feel that we do not provide an exhaustive coverage of their research areas. When possible, we point the reader towards more specialized surveys. There are also several general surveys on systemic risk: [De Bandt and Hartmann \(2002\)](#), updated in [De Bandt, Hartmann, and Peydró \(2012\)](#), is an early and comprehensive survey on the topic, [Bisias *et al.* \(2012\)](#) give a broad overview of how to quantify systemic risk, and [Glasserman and Young \(2015\)](#) focus on the theoretical understanding of the relationship between interconnectedness and financial stability. In their monograph, [Freixas, Laeven, and Peydró \(2015\)](#) offer a framework for understanding the reasons for the regulatory shift from a microprudential approach to a macroprudential approach to financial regulation. Our angle differs from existing surveys as we focus on matching sources of systemic risk, current regulation, econometric modeling tools, as well as evaluations of these tools. We hope that through this survey our readers will gain a better understanding of where the risks lie.

2 Sources of systemic risk

Before surveying the theoretical literature, it is useful to consider a simple conceptual framework that delivers some preliminary distinctions. We keep it deliberately abstract so as to encompass several strands of the literature.

Consider N financial institutions indexed by i , each with a risk exposure x_i . A proportion α_i of the exposure concerns a systematic risk factor, while $1 - \alpha_i$ concerns a risk factor idiosyncratic to i . We denote $y_i^S = \alpha_i x_i$ the systematic exposure and $y_i^I = (1 - \alpha_i)x_i$ the idiosyncratic exposure of institution i . We also denote $y^S = \sum_{i=1}^N y_i^S$ the cumulative exposure to systematic risk for all institutions. In addition, financial institutions have direct “links” among each other, for instance interbank loans or derivatives, given by the $N \times N$ matrix B , whose elements $b_{i,j}$ denote how much i is exposed to j .

The returns on the systematic and i 's idiosyncratic factors are $\rho^S + \varepsilon^S$ and $\rho^i + \varepsilon^i$, respectively, where ρ^S and ρ^i are constants, while ε^S and all the ε^i are independently distributed random variables with zero mean. We define the benchmark payoff $\hat{\pi}_i$ as what i would receive

if there were no other institutions in the system. We can write it in general as $\hat{\pi}_i(y_i^S, y_i^I, \varepsilon^S, \varepsilon^i)$. For illustration, a simple specification would be:

$$\hat{\pi}_i = (\rho^S + \varepsilon^S) \times y_i^S + (\rho^i + \varepsilon^i) \times y_i^I. \quad (1)$$

Since all institutions are exposed to the systematic factor, they can all suffer losses simultaneously simply because a large negative shock ε^S occurs. We will call this form of risk, which is present for instance in a standard CAPM framework, *systematic risk*.

However, there is more to systemic risk than just systematic risk. As i belongs to a system of financial institutions, its actual payoff differs from $\hat{\pi}_i$ and depends on the exposures of other institutions, the idiosyncratic shocks they face, and on the links of i with other institutions, or even among these other institutions. Denoting π_i the actual payoff of i , \mathcal{E}^I , Y^S , and Y^I , the $N \times 1$ vectors of idiosyncratic shocks, systematic exposures, and idiosyncratic exposures, respectively, π_i writes as $\pi_i(Y^S, Y^I, B, \varepsilon^S, \mathcal{E}^I)$. A defining characteristic of *systemic risk* is that $\pi_i(Y^S, Y^I, B, \varepsilon^S, \mathcal{E}^I) \neq \hat{\pi}_i(y_i^S, y_i^I, \varepsilon^S, \varepsilon^i)$, at least for some values of the variables. The exact definition of systemic risk varies across papers but in general a systemic event will be a joint statement about the π_i .¹

In this section, we review models explaining the different sources of systemic risk, or the determinants of the joint distribution of the π_i . The specification of how π_i depends on its parameters and the trade-offs underlying the optimal choice of α_i , x_i , and other variables are of course specific to each paper. However, it is useful to define three categories of economic mechanisms in our framework:

Systemic risk-taking mechanisms explain the distribution of the x_i and α_i in the system. In particular, financial institutions take too much systemic risk if they endogenously choose an exposure x_i and its systematic component $\alpha_i x_i$ that are higher than the welfare-maximizing values of these variables.

Contagion mechanisms rationalize that π_i is lower when some institution j suffers a loss, even when this loss only stems from its idiosyncratic exposure ε^j . These mechanisms typically work through the matrix of links B . A defining criterion of contagion effects is that the payoffs

¹Systemic risk can be for instance the probability that all the π_i are below a certain threshold (for instance the one that triggers default), or that their sum is very negative, etc.

of two institutions are positively correlated, even when there is no systematic shock:

$$\text{Cov}(\pi_i, \pi_j | \varepsilon^S = 0) > 0. \quad (2)$$

Amplification mechanisms explain why small shocks, for instance to the systematic factor, can turn into large losses if they affect many institutions. An example would be deleveraging: a small negative shock ε^S strongly affects the institutions with a high y_i^S , they need to sell their assets and exert a price impact that worsens the losses to other market participants, and so on. Amplification depends on the y_i^S of all institutions, and typically on their sum, y^S . A feature of the papers that highlight this mechanism is that the effect of a systematic shock ε^S is greater when the cumulative exposure to this shock y^S is larger:

$$\frac{\partial^2 \mathbb{E}(\pi_i)}{\partial \varepsilon^S \partial y^S} > 0. \quad (3)$$

Of course, several mechanisms can be combined. An idiosyncratic shock on i can force this institution to deleverage, which has an important impact on market prices if y_i^S is large. If α_j^S is large, this price impact will hurt j , who also directly suffers from i 's default depending on $b_{j,i}$. The combination of both effects may lead to j defaulting, which will in turn affect k , and so on. Figure 2 illustrates these systemic loops.

Using this simple conceptual framework, we organize our survey of the literature around the three aforementioned mechanisms.²

2.1 Systemic risk-taking

In the terms of our theoretical framework, the literature concerned with “systemic risk-taking” studies why financial institutions choose to be exposed to similar risks (they choose a high α_i), thus reinforcing amplification mechanisms, and why they take large risk exposures (large x_i), exposing themselves to default and their counterparts to contagion.³

Correlated investments. Financial institutions will be exposed to the same risks if they invest in the same assets. Several mechanisms can lead to this outcome. In Acharya (2001, 2009), the failure of one bank leads to a lower aggregate level of risky investment, which raises the rate of return on the safe asset in equilibrium, and squeezes the surviving bank's

²It should be clear that the ambition of this framework is limited to providing a tool to organize our survey. Full-fledged models can be found for instance in Acharya *et al.* (2010), Gouriéroux, Héam, and Monfort (2012), or Greenwood, Landier, and Thesmar (2015).

³We postpone the discussion of how the links $b_{i,j}$ are formed to the next section.

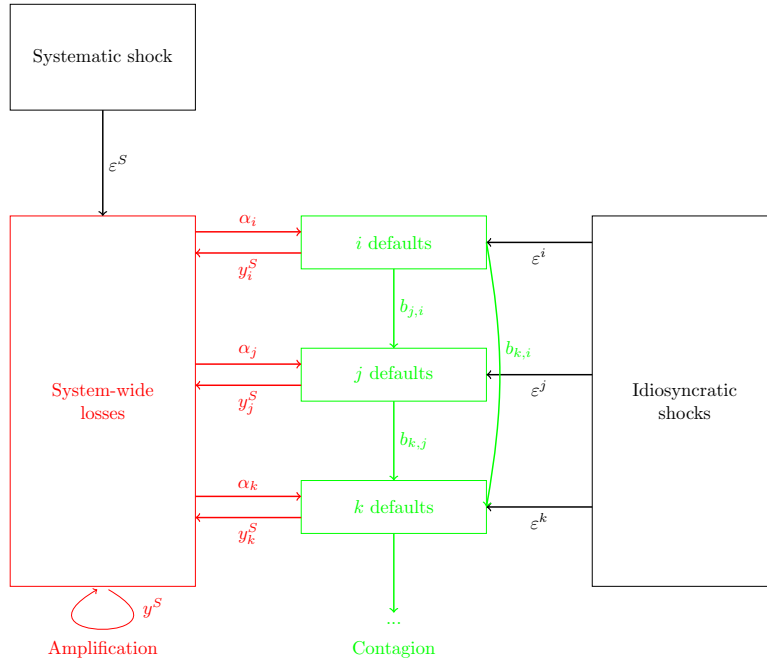

Figure 2: Systemic Loops. The green sector of the figure represents contagion mechanisms and the red sector amplification mechanisms. Each edge represents a risk transmission channel, whose strength is given by the label on the edge. For example, the sensitivity of j to system-wide losses is measured by α_j , while j 's contribution to system-wide losses depends on y_j^S .

profits. The failed bank thus imposes a negative externality, a “recessionary spillover”, on the surviving bank. In order to minimize this externality, banks have incentives to invest in the same assets and thus fail or survive together. A similar mechanism is studied in Acharya and Yorulmazer (2008b), in which the externality is that creditors rationally interpret the default of a given bank as a signal that other banks may fail in the future. In Acharya and Yorulmazer (2008a), regulation itself generates a herding behavior: when banks fail together, the liquidation of their assets would have a large impact on the economy, which forces the government to organize a bail-out. By taking the same risks, banks maximize the benefits from future bail-outs, and enjoy a “too-many-to-fail” guarantee. Farhi and Tirole (2012) derive a similar result under the simple assumption that many forms of bail-outs involve a fixed cost for the government (e.g. maintaining low interest rates, thus affecting the entire economy). Bail-outs are then optimal only when many banks fail at the same time, so that banks optimally engage in herding.⁴

⁴There are countervailing forces to herding. An important one is the “last bank standing effect” of Perotti and Suarez (2002): if a bank does not engage in herding, it is in a good position to buy other banks’ assets at

Liquidity risk. Another form of risk to which banks tend to be exposed to in a correlated manner is liquidity risk. In a foresighted contribution, [Bhattacharya and Gale \(1987\)](#) show that banks invest too much in illiquid assets, thus exposing the banking system to the risk of aggregate liquidity shortages. The reason is a free-riding problem: it would be collectively optimal that some banks invest in assets that can be easily liquidated. If some banks face an expected liquidity withdrawal, they borrow on the interbank market from the banks with liquid assets, which liquidate some of their holdings to finance the loan. There is thus an incentive to invest in illiquid assets only and rely on other banks to find liquidity if a shock hits the system. In equilibrium, all banks over-invest in illiquid assets, so that they are all hit when a liquidity shock occurs. Banks’ liabilities can also be too liquid, thus reinforcing the mismatch between assets and liabilities. [Brunnermeier and Oehmke \(2013b\)](#) show that a firm can dilute the claims of existing creditors by issuing new debt at shorter maturity. Creditors anticipate this behavior and offer better interest rates for short maturities. The outcome is a “maturity rat race” that leads all banks to rely on excessively short-term debt.⁵

Tail risks. It is necessary for systemic events to materialize that banks’ risk exposures are not only correlated, but also large (in our theoretical framework, x_i must be high). There is an extensive literature on bank risk-taking, which is outside the scope of our survey, but a particularly relevant strand of this literature concerns tail risks, which will be an important source of contagion and amplification when extreme events occur. [Perotti, Ratnovski, and Vlahu \(2011\)](#) show that traditional capital requirements incentivize banks to substitute normal risks, which are taken into account by the regulatory framework, with tail risks, which are not adequately priced. [Acharya *et al.* \(2010b\)](#) claim that the shadow banking system was precisely used to organize such a “manufacturing of tail risk” in the run-up to the crisis. In addition to this regulatory arbitrage motive, investors may also fail to adequately discipline this form of risk-taking by financial institutions.⁶ [Gennaioli, Shleifer, and Vishny \(2013\)](#) show

fire-sale prices when they are simultaneously hit by a negative shock.

⁵An interesting special case arises when a maturity mismatch is coupled with foreign exchange mismatches. Those arise when a bank finances a loan in a foreign currency and loses access to short-term funding in that same currency. The central bank cannot act as a lender of last resort in such a situation, as it can only lend in the domestic currency. This mechanism arguably played a significant role in the 1997 Asian crisis. In order to avoid such effects in 2007-2009, various central banks set up FX swap mechanisms among each other (see [Allen and Moessner \(2010\)](#) and [Moessner and Allen \(2013\)](#)).

⁶An interesting example is given in [Chan *et al.* \(2007\)](#), who argue that many hedge funds loaded on tail risk precisely because it was difficult for investors to disentangle tail risk-taking from genuine alpha.

that investors’ myopia to tail risks can turn the shadow banking technology into a source of systemic risk. Moreover, as tail events are rarely observed, it is difficult for investors to identify and punish institutions that engage in such strategies. The literature on dynamic moral hazard studies how to deal with this problem, see e.g. [Biais *et al.* \(2010\)](#) or [Freixas and Rochet \(2013\)](#) for models deriving implications for systemic financial institutions.

Leverage cycles and bubbles. An important form of systemic risk-taking is that banks tend to increase their risk exposures in a correlated manner, that is the x_i of our theoretical framework are positively correlated. A mechanism explaining this behavior, well explored in the macro-finance literature, is the leverage cycle. Due to the limited pledgeability of future income, many borrowers are not able to access funding by lack of collateral. This constraint implies that households, firms, and financial institutions can borrow more when the value of their assets is high than in bad times, when asset prices are depressed. [Bernanke and Gertler \(1989\)](#), [Kiyotaki and Moore \(1997\)](#), [Geanakoplos \(1997\)](#), and [Holmstrom and Tirole \(1997\)](#) proposed extremely influential models that lead to such an outcome.⁷ The macro-finance literature has built on these seminal papers to better understand the link between business cycles and financial cycles. We cannot do justice to this growing literature, which is surveyed by [Brunnermeier, Eisenbach, and Sannikov \(2013\)](#). More recent contributions include for instance [Brunnermeier and Sannikov \(2014\)](#) or [Boissay, Collard, and Smets \(2015\)](#).

In a related vein, a series of papers model the behavior of financial institutions subject to realistic risk-management or regulatory constraints. In [Daniélsson, Shin, and Zigrand \(2004\)](#) for instance, financial institutions face a VaR constraint. As the VaR increases in volatile periods, institutions typically invest more in good times and deleverage in bad times. This behavior generates procyclical leverage in the financial industry and thus gives both a rationale for fragility building up in good times and an amplification mechanism in bad times (see also [Adrian and Shin \(2014\)](#)).⁸ A different source of leverage cycles is investors’ beliefs: [Bhattacharya *et al.* \(2011\)](#) offer a formal model of the “Minsky financial instability hypothesis” ([Minsky \(1992\)](#)), according to which investors become more optimistic in a prolonged expansion and thus take more risks.

⁷[Geanakoplos \(1997\)](#) in particular derives the collateral constraint endogenously in a general equilibrium framework. See [Fostel and Geanakoplos \(2014\)](#) for a survey of this research program.

⁸In a recent study, [Benoit, Hurlin, and Pérignon \(2015\)](#) confirm this mechanism and propose the FIRE methodology to test for the regulation-induced comovement in risk exposures across banks.

While the economic mechanism is different, the formation of bubbles typically implies that financial institutions simultaneously take large positions in the same assets, with a high risk that their value will drop at some future date. [Brunnermeier and Oehmke \(2013a\)](#) provide an in-depth survey of the theoretical literature on bubbles. Notice that bubbles can also be linked to leverage cycles. [Allen and Gale \(2000a\)](#) for instance show that leveraged investors have an incentive to bid up asset prices, as they can default if their losses are too large, so that agency problems between borrowers and creditors generate bubbles and crises. [Allen and Carletti \(2013\)](#) build on this model to explore real estate bubbles, a dominant feature of the recent crisis. Bubbles can also be generated by the optimal compensation package of loan officers ([Acharya and Naqvi \(2012\)](#)).

2.2 Contagion between financial institutions

Contagion occurs when losses in one financial institution spillover to other institutions that are linked with the first one. In our theoretical framework, the potential for direct contagion from j to i is measured by $b_{i,j}$. The literature has explored several forms of bilateral links as well as the impact they have on the stability of the system.

Balance-sheet contagion and networks. A typical example of links is interbank claims, in which case $b_{i,j}$ simply measures how much j owes to i . While it is clear that the presence of such links can propagate bank defaults through domino effects, how the risk of a systemic event depends on the whole matrix B is a much subtler question. [Allen and Gale \(2000b\)](#) show that interbank markets also allow banks to engage in risk-sharing. This reduces the probability that any bank defaults, introducing a potential trade-off between the occurrence of one default and contagion effects. They show that complete networks, in which $b_{i,j}$ is positive for each pair, are more robust than connected but incomplete networks, in which for instance i is linked to j and j to k , but i has no direct link to k . The intuition for this result is that an indirect link between i and k is enough to generate contagion between them, but i and k do not insure each other unless they are directly linked. More generally, risk-sharing and propagation risks will be different depending on the links formed by banks. In one of the first papers to discuss the case of a general matrix of interbank exposures, [Freixas, Parigi, and Rochet \(2000\)](#) show that a circular chain of banks is less robust than a complete network and discuss the formation of interbank links (in particular the issue of coordination failures). In

a similar logic, [Allen, Babus, and Carletti \(2012\)](#) show that having separate clusters of banks reduces contagion compared to a complete network but also decreases incentives to roll-over short-term debt.

The literature on banking networks has emerged to study which general properties of a network reinforce contagion. This is made possible by the methodological contribution of [Eisenberg and Noe \(2001\)](#), who show how to price interbank claims when banks' liabilities are other banks' assets (a circularity problem). Important results in this literature include for instance the idea that networks are “robust yet fragile” ([Gai and Kapadia \(2010\)](#)), see also [Acemoglu, Ozdaglar, and Tahbaz-Salehi \(2015\)](#)): connected networks, in which all institutions are connected to each other (at least indirectly) are more robust to shocks, because of risk-sharing, but are more likely to see all institutions fail conditional on a large shock.⁹ [Elliott, Golub, and Jackson \(2014\)](#) study the role of two intuitive properties of an interbank network, namely integration (how much banks rely on other banks) and diversification (number of banks on which a given bank's liabilities are spread over).

A natural follow-up on this literature is to study which types of networks are formed by profit-maximizing banks, or how the links $b_{i,j}$ are determined in equilibrium. The answer is complex and sensitive to how interbank linkages are modeled. [Leitner \(2005\)](#) shows that banks can voluntarily form bilateral links and expose themselves to contagion risk in order to commit to helping each other during a liquidity crisis. Indeed, in a densely connected network, a bank A with a surplus of liquidity may prefer lending to a bank B in trouble rather than let B default, which could trigger contagious defaults that would ultimately hurt A . Interbank linkages can thus generate “private bail-outs”. Whereas this first paper focuses on studying fully connected networks, many papers document the prevalence of core-periphery networks in real-world banking systems, starting with [Boss *et al.* \(2004\)](#), so that such networks (as well as more stylized “star networks”) have attracted the attention of later theoretical work (see for instance [Babus \(2015\)](#), [Castiglionesi and Navarro \(2011\)](#), [Farboodi \(2015\)](#), and [Babus and Hu \(2015\)](#)).¹⁰ A different approach is to use more intricate models and calibrate them on real-world networks, as done by e.g. [Anand *et al.* \(2013\)](#) and [Gofman \(2015\)](#). [Allen](#)

⁹[Nier *et al.* \(2007\)](#) more generally consider the impact of a network's connectivity on contagion.

¹⁰Alternatively, [Babus and Kondor \(2013\)](#) consider an exogenous dealer network and endogenize the bilateral trading volume between the different dealers. They show that stylized facts observed on such networks during the crisis correspond to what happens when some links between dealers are severed in their model, which could be due to concerns about counterparty risk.

and Babus (2009) provide a more detailed survey of the literature on interbank markets and financial networks.

Payment and clearing infrastructures. Banks make payments to each other as a result of their clients' operations. Freixas and Parigi (1998) show that a net system, in which interbank net positions are settled at the end of the day only, efficiently allows banks to keep less reserves but also exposes them to contagion as it implies interbank credit, leading to a trade-off. Rochet and Tirole (1996a) discuss how both gross and net systems can coexist, while Holthausen and Rønde (2002) explore regulatory issues. Afonso and Shin (2011) discuss the possibility of freezes, and show that mechanical rules used by banks for sending payments in normal times can quickly lead to important disruptions in periods of stress.¹¹

Central counterparties (CCPs) are financial infrastructures that have gained increasing attention in the systemic risk literature. This interest was sparked by the global reform of over-the-counter (OTC) derivatives market that mandates central clearing of all standardized derivative contracts. Zawadowski (2013) models a financial system in which banks hedge their portfolio risks using OTC derivatives but they do not hedge the counterparty risk associated with these contracts. In this setting, an idiosyncratic bank failure can lead to a systemic run of lenders. Acharya and Bisin (2014) show that a counterparty risk externality arises in opaque OTC markets, but not when trading is organized via a centralized clearing mechanism. Koepl, Monnet, and Temzelides (2012) and Biais, Heider, and Hoerova (2015) analyze the optimal design of clearing arrangements, taking into account the moral hazard problem associated with counterparty risk. Duffie and Zhu (2011) formally show that reducing the number of CCPs, ideally to one, would lower counterparty exposure and collateral demand. Finally, Duffie (2014) reviews some alternative approaches to failure resolution for CCPs.

Informational contagion. One last form of bilateral links is information. Indeed, if depositors and investors believe that the failure of bank j is a signal on the health of bank i , then there is an informational link $b_{i,j}$ between these two banks, and potential for contagion. In Chen (1999) for instance, banks' returns are correlated, so that observing a run on one bank makes uninformed depositors run on other, correlated banks, turning a bank run into a banking panic (see also Aghion, Bolton, and Dewatripont (2000) and Acharya and Thakor (2015)). In

¹¹McAndrews and Potter (2002) study the systemic event on the US payment system that was triggered by the terrorist attacks of September 11, 2001.

Dasgupta (2004), banks are linked through cross-deposits so that negative information about one bank starts a run in both the affected bank and the ones to which it is linked. Cespa and Foucault (2014) show that market illiquidity itself is contagious, so that a drop in liquidity for one asset can trigger a similar drop in other correlated assets, thus propagating problems.¹²

2.3 Amplification mechanisms

A number of mechanisms have been proposed to explain why relatively small shocks can lead to large aggregate impacts, in particular when they simultaneously affect many institutions (as does ε^S in our framework).

Liquidity-driven crises. The self-reinforcing nature of liquidity crises is probably the best example of amplification. When market prices drop, financial intermediaries need to liquidate their assets to meet funding and collateral constraints.¹³ These new sales amplify the downturn, leading to further sales, and so on. Allen and Gale (2004b) show that the fundamental market failure behind this effect is market incompleteness: if there are not enough contingent securities to efficiently allocate liquidity in each state, liquidity has to be found ex post by liquidating assets. Liquidity shocks thus have large effects on market prices (Allen and Gale (1994) and Allen and Gale (2004a)).¹⁴ Shleifer and Vishny (1992) find a related rationale for “fire sales”: agents investing in an asset need to gather information and become “specialists”. When a negative shock hits the value of the asset and many specialists need to liquidate their positions, only less-informed outsiders can buy, and they ask for a lower price (see Coval and Stafford (2007) for empirical evidence). Financial constraints on arbitrageurs’ positions also amplify crises by magnifying the impact of transient shocks (Shleifer and Vishny (1997), Gromb and Vayanos (2002)).

Brunnermeier and Pedersen (2009) propose a model in which the snowball effects just described, a “loss spiral”, interacts with the fact that margin requirements increase when the market becomes less liquid, a “margin spiral”. Losses on one asset induce market participants

¹²Calomiris and Mason (1997) study the Chicago banking panic of 1932 and find little evidence that contagion led to the failure of fundamentally solvent banks. Bae, Karolyi, and Stulz (2003) for instance propose measures of financial market contagion across countries and regions.

¹³A concrete example is the requirement to mark-to-market trading positions, as studied in Plantin, Sapra, and Shin (2008).

¹⁴This market failure is closely related to the works on leverage cycles. In both cases, the fundamental problem is the constrained inefficiency of incomplete markets, as studied in Stiglitz (1982) and Geanakoplos and Polemarchakis (1986).

to reduce their positions. Their sales depress market prices, implying further losses. Moreover, market liquidity is reduced, which prompts financiers to apply higher margin requirements. Both effects reinforce the pressure to sell the asset, but also other assets held by the same market participants. Liquidity spirals are thus a source of contagion across different assets, or asset classes.¹⁵ Other papers have shown that amplification mechanisms can additionally lead to contagion. In [Diamond and Rajan \(2005\)](#), a run on one bank leads to inefficient early liquidation, implying a lower level of aggregate liquidity in the next period and contagious runs on additional banks. For asset markets, [Cifuentes, Shin, and Ferrucci \(2005\)](#) study contagion due to liquidations driven by mark-to-market accounting. [Kodres and Pritsker \(2002\)](#) introduce an information-based mechanism: agents who make losses on one asset liquidate their holdings both of this asset and other assets they hold. As other investors do not know whether these sales are information or liquidity-driven, the price of the other assets will also decrease.

Market freezes. An extreme form of illiquidity is the case of a market freeze. Interbank markets in particular have proved to be particularly fragile during the 2008 crisis. In [Flannery \(1996\)](#), lenders on the interbank market face an adverse selection problem because they cannot tell safe from risky banks. As a result, safe but illiquid banks may not access funding and a lender of last resort is necessary. [Heider, Hoerova, and Holthausen \(2015\)](#) build a more complete model showing how asymmetric information can lead to several regimes on the interbank market, including a market breakdown, and compare their results with the events during the financial crisis. As repo markets were particularly hit during the crisis, they have been more specifically studied in several papers. [Gorton and Ordonez \(2014\)](#) show that it is optimal to choose as collateral assets with a low sensitivity to information, meaning that not much can be learnt about the asset's fundamental value (e.g. government bonds or AAA securities). In normal times, agents optimally choose not to acquire any information about the asset and are thus symmetrically uninformed, which makes trade possible. After a negative shock, some agents start acquiring information about the asset used as collateral. Asymmetric information problems thus arise endogenously in bad times, which can lead to a freeze of the repo market. [Acharya, Gale, and Yorulmazer \(2011\)](#) show that repo chains can

¹⁵[Boyson, Stahel, and Stulz \(2010\)](#) find evidence for contagion of losses across different style categories of hedge funds, and link this contagion to liquidity shocks, in line with the [Brunnermeier and Pedersen \(2009\)](#) model.

entirely collapse when the market suddenly becomes pessimistic about the value of an asset used as collateral.

Some papers have studied market breakdown mechanisms going beyond traditional adverse selection. In [Caballero and Simsek \(2013\)](#), banks know whether their counterparties have been hit by a negative shock, but know nothing about their counterparties' counterparties and other banks further away in the counterparty chain. As a result, banks have little information about the actual counterparty risk they face, and thus stop lending to each other after large shocks, as happened around the failure of Lehman Brothers. [Morris and Shin \(2012\)](#) explain market freezes for “toxic assets” by the breakdown of common knowledge about the maximum losses that can be made when holding them. [Arora *et al.* \(2009\)](#) study how computational complexity can create a form of adverse selection, which is typically relevant for complex structured products.

Coordination failures and runs. A classical explanation of how small shocks can lead to systemic events is that banks and other financial institutions are inherently fragile, due to coordination problems between their creditors. The extensive literature on bank runs, dating back to the seminal contributions of [Bryant \(1980\)](#) and [Diamond and Dybvig \(1983\)](#), and later, e.g., [Calomiris and Kahn \(1991\)](#) and [Goldstein and Pauzner \(2005\)](#), is primarily concerned with this problem (see [Freixas and Rochet \(2008\)](#) for a survey). Research in recent years has shown that the institutional settings of modern financial markets may make them more fragile than initially thought, in particular due to heavy reliance on short-term funding (rationalized by [Brunnermeier and Oehmke \(2013b\)](#), as already discussed). [He and Xiong \(2012\)](#) show that the creditors of a firm will roll-over short-term debt only if they expect future creditors to do the same, so that “dynamic debt runs” are possible. [Martin, Skeie, and Von Thadden \(2014\)](#) extend the bank run literature with the features of modern markets for wholesale funding, showing in particular the importance of contracting conventions in the repo market.¹⁶ [Duffie \(2010\)](#) discusses how dealer banks can simultaneously suffer a variety of runs from their different types of counterparties. [Lagunoff and Schreft \(2001\)](#) and [Bernardo and Welch \(2004\)](#) also introduce the idea of financial market runs, in which market participants liquidate their positions because they fear that others will sell and depress prices.¹⁷

¹⁶Interestingly, they emphasize the role of larger haircuts in allowing creditors to maintain lending while [Gorton and Metrick \(2012\)](#) interpret the increase in haircuts as evidence of a run in 2007-8.

¹⁷[Chen, Goldstein, and Jiang \(2010\)](#) provide evidence of such a strategic complementarity using data on

3 Regulation

The financial crisis has triggered a bloom of new regulatory tools and agencies at the global level, as well as proposals from academics to go further in regulating systemic risk. This regulatory update being unprecedented in its scope and magnitude, it is challenging to get an overview of the regulation of systemic risk. We give a brief discussion of the main tools and then summarize recent changes in the regulatory framework.¹⁸

3.1 Old and new tools to counter systemic risk

The most visible reform at the international level are the new Basel III rules (BCBS (2011)), which include in particular higher capital requirements with a countercyclical component, a framework for liquidity regulation, and additional measures for SIFIs. The accounting standard IFRS10 on consolidated financial statements now makes it more difficult to hide risk off balance sheet. In addition, a number of other supervisory measures or macroprudential tools have met with renewed interest since the crisis, such as sectoral capital requirements and caps on loan-to-value ratios. These different updates can be understood as trying to address the three categories of systemic weaknesses we underlined in the previous section.

Systemic risk-taking. Basel III imposes both higher capital ratios and a stricter definition of capital.¹⁹ In addition, banks have to respect a 3% leverage ratio limit, based on non-risk weighted assets only (BCBS (2014c)). This should give all banks more “skin in the game” and reduce risk-taking in general, not only systemic risk-taking. Preventing banks from taking similar bets is more difficult, and requires more targeted, macroprudential tools. Sectoral capital requirements for instance allow supervisors to ask banks to maintain higher capital ratios when lending to particular sectors of the economy, which can be used to discourage lending in sectors to which the banking system is already heavily exposed. Caps on loan-to-value ratios directly target mortgage loans, and can be used to prevent the formation of housing bubbles, which crucially rely on leveraged financing (see Ono *et al.* (2013) for

mutual funds.

¹⁸Galati and Moessner (2013) offer a detailed survey of macroprudential tools. See also Claessens (2014) for a discussion of the interaction between macroprudential tools and other instruments, such as monetary policy or microprudential regulation, and Crowe, Dell’Ariccia, Igan, and Rabanal (2013) for a survey of macroprudential tools aimed at preventing real estate boom and bust cycles.

¹⁹The minimum ratio is 8.5% Tier 1 Capital, 7% of which must be common equity (BCBS (2011)). These numbers include the 2.5% “conservation buffer”, below which banks are not allowed to distribute dividends.

evidence on these tools).

The newest regulatory measures introduced by Basel III are the liquidity requirements, whose goal is to decrease the maturity mismatch in the banking sector *ex ante*, and thus limit the need for banks to liquidate their assets and generate large market downturns *ex post*. The Liquidity Coverage Ratio (LCR, [BCBS \(2013a\)](#)) requires banks to hold fractional reserves of liquid assets to meet short-term liquidity needs, and the Net Stable Funding Ratios (NSFR, [BCBS \(2014a\)](#)) imposes an upper limit on short-term debt to reduce overall funding liquidity risk. While few papers have studied these tools theoretically, their optimality is sometimes called into question. [Perotti and Suarez \(2011\)](#) for instance show that regulating liquidity via quantities is distortive, and propose a tax on liquidity risk instead. [Tirole \(2011\)](#) suggests to monitor liquidity but through a quality perspective instead of a quantitative view, since some liquid assets are potentially toxic. [Jobst \(2014\)](#) gives an overview of the different instruments proposed by academics.

Basel III also introduces countercyclical capital buffers, which are supposed to smoothen the leverage cycle, and in particular to reduce the procyclicality introduced by the Basel capital requirements themselves. Indeed, as capital requirements increase in more volatile times, banks are requested to deleverage in crises and face looser constraints in booms, amplifying market fluctuations. [Aiyar, Calomiris, and Wieladek \(2014\)](#) offer some evidence on the likely impact of countercyclical capital buffers. Using British data, they observe that the drop in credit supply after an increase in capital requirements is partially offset by an increase in lending by foreign branches, which are unaffected by the regulatory tightening. The impact of rising capital requirements in good time and lowering them in bad times will thus be significantly reduced by this substitution effect.²⁰ Other tools have been discussed to reduce risk-taking in good times. [Bianchi and Mendoza \(2015\)](#) for instance propose a “macroprudential debt tax” aimed at reducing financial institutions’ leverage when the probability of a crisis is high. [Stein \(2012\)](#) shows that private money creation leads banks to issue too much short-term debt, which can be seen as a negative externality. Open market operations are a way to allocate “permits” for monetary creation, in a way similar to the regulation of carbon emissions, so that monetary policy can be seen as a form of financial stability regulation.

²⁰See also [Jimenez *et al.* \(2014\)](#) for more positive evidence, showing that the experimentation with such countercyclical tools in Spain in the 2000s smoothed the credit cycle.

A challenge in the literature is to build quantitative models that can inform the decision of policy-makers. [Clerc *et al.* \(2015\)](#) develop a rich model to calibrate optimal capital requirements that vary over the business cycle. [Goodhart *et al.* \(2012\)](#) study a framework in which several of the tools currently used by regulators interact, in particular loan-to-value ratios, dynamic provisioning, and liquidity requirements.

Discouraging herding behavior is probably the weak point of Basel III. The Asymptotic Single Risk Factor Model, still at the heart of the Basel approach to computing capital requirements, assumes that all banks have a maximally diversified portfolio and, as a result, are all exposed to the same single risk factor. As pointed out by [Wagner \(2010\)](#), there is a trade-off between ensuring that all banks have the same prudent behavior, and encouraging heterogeneity in risk-taking. There is a possibility that recent reforms actually encourage more correlation across banks. Stress-tests for instance require all banks to have enough capital to withstand the same shocks, which discourages some of them to take contrarian bets. As a consequence, regulators may end up imposing their own views about risk on banks.²¹

Contagion. Fewer regulatory reforms are targeted at reducing contagion risk. The BCBS had long recommended to take action against large and concentrated exposures in banks' portfolios ([BCBS \(1991\)](#)), the problem being that the Basel framework as a whole de facto relies on the assumption that banks have infinitely granular portfolios. [BCBS \(2014b\)](#) strengthens the so-called "large exposure limits" for banks, and now mentions limiting contagion risk as a new objective, in particular for SIFIs. Some academics have called for a more radical reform to deal with contagion. A possibility would be to base capital requirements not on the risk of individual assets, but on their systemic importance. [Allen and Gale \(2007\)](#) and [Morris and Shin \(2008\)](#) show that capital requirements that do not take into account the structure of interconnections among banks can actually increase risk. Capital requirements should thus be "system weighted". [Alter, Craig, and Raupach \(2015\)](#) show how to compute and apply such capital requirements, based on the centrality of a bank in the interbank market.

Some authors call for a more radical shift in the regulatory perspective. For instance, [Acharya and Öncü \(2013\)](#) suggest that regulators should not focus on individual institutions, but identify which assets and liabilities have a systemic impact, and limit or regulate their use.

²¹See [Bernanke \(2013\)](#) for a discussion of this problem. A similar point is made by [Daníelsson \(2008\)](#) on the risk that regulators might become "risk-modelers of last resort".

For [Rochet \(2010\)](#), there is little evidence that bilateral interbank networks were efficient at providing peer monitoring before the crisis (as studied in [Rochet and Tirole \(1996b\)](#)), so that there can be only benefits in centralizing interbank trades on CCPs. The regulatory focus can then be shifted from the individual institutions to ensuring the safety of the CCP, and other centralized platforms. More generally, [Duffie \(2013\)](#) discusses different regulatory measures to ensure the robustness of the “plumbing” of the financial system, i.e., the infrastructure through which cash and risk are transferred. For example, regulators are imposing the compulsory clearing of standardized OTC derivatives and try to regulate exposures at this level ([BCBS-IOSCO \(2013\)](#)). In addition, non-centrally cleared OTC derivatives are subject to mandatory margin requirements (see [Duffie, Scheicher, and Vuillemeys \(2015\)](#) for an overview and an estimate of the impact of these new rules).

Amplification mechanisms. The occurrence or threat of bank runs, either in traditional banks or in the shadow banking sector, led to extensions of deposit insurance. Its threshold was increased and harmonized to 100,000 EUR per account across the Euro area following the events in Cyprus in 2013. In the US, the run on Primary Reserve Fund on September 16, 2008 led to a temporary extension of deposit insurance to money market mutual funds. Many central banks strengthened their lending of last resort framework to alleviate tensions in interbank markets. The ECB expanded the set of assets accepted as collateral when lending to banks, and increased its balance sheet from about 1,450 bln EUR in September 2008 to 3,100 bln EUR in July 2012, to a large extent substituting for the interbank market at the peak of the crisis. To avoid massive bank failures and restart markets for “toxic” assets, frozen by asymmetric information concerns, the US government launched its 475 bln USD TARP program in 2008.²²

While providing relief to the financial sector is optimal ex post, the academic literature has repeatedly pointed out that such a behavior destroys market discipline and is thus an important source of systemic risk-taking,²³ in particular when banks become “too-big-to-fail”.²⁴ Despite the size of the bail-outs organized during the crisis, or because of it, there

²²See [Tirole \(2012\)](#) and [Philippon and Skreta \(2012\)](#) for theoretical analyses.

²³See [Allen, Carletti, Goldstein, and Leonello \(2015\)](#) for a recent analysis of this trade-off, in the context of government guarantees to banks in general.

²⁴See [O’Hara and Shaw \(1990\)](#) for early evidence on this problem during the Continental Illinois crisis. [Oliveira, Schiozer, and Barros \(2015\)](#) study the impact of being perceived as too-big-to-fail on deposit-taking and cost of capital for Brazilian banks during the 2008 crisis. [Gormley, Johnson, and Rhee \(2015\)](#) document

has been substantial effort to increase the credibility that bail-outs can be avoided and future losses be borne by creditors. Title II of the 2010 Dodd-Frank Act strengthens the resolution powers of the Federal Deposit Insurance Corporation and the Federal Reserve (Fed) and formalizes the liquidation process in order to have a more predictable “orderly liquidation”. An interesting innovation is to force banks to prepare plans that would facilitate their resolution in the event of financial distress or failure, the so-called “living wills”.²⁵ Academics have proposed additional tools to deal with resolution. The Squam Lake Group, a group of finance academics who offer guidance on the reform of financial regulation, issued a report encouraging financial institutions to issue contingent convertible securities (cocos) which allow to reduce an institution’s leverage in a crisis period.²⁶ Freixas and Rochet (2013) model the problem of regulating a too-big-to-fail SIFI. The optimal regulation in such a case is complex, involving at the same time a systemic risk authority endowed with special resolution powers, a systemic risk tax, and controls on bank managers’ compensation packages.

Perhaps the most significant development of bank regulation in recent years is the increased reliance on stress-tests. They help the regulator to identify banks that are vulnerable, and also provide an additional check that a bank’s capital can meet particularly adverse scenarios.²⁷ A recent innovation is to publicly disclose stress-test results so as to reduce opacity and asymmetric information about banks’ positions. The Fed tried this approach for the first time with the 2009 Supervisory Capital Assessment Program, as part of the TARP program. The EBA also regularly publishes stress-test results. In particular, it published detailed data about European banks’ sovereign exposures in 2011 in order to ensure that markets were symmetrically informed about banks’ risk exposures. Bouvard, Chaigneau, and De Motta (2015) show that revealing information about banks can avoid runs due to fears that turn out to be unfounded, but the same policy can also help market participants to focus on equilibria with runs. In Goldstein and Leitner (2015), disclosing stress-test results can destroy opportunities for risk-sharing.²⁸

the failure of a policy designed to end the too-big-to-fail perception in the South Korean banking sector.

²⁵See also the final Total Loss-Absorbing Capacity standards issued by the FSB (FSB (2015)).

²⁶The merits of cocos are debated. See for instance Sundaesan and Wang (2015).

²⁷In the US, large banks are required to pass two annual stress-test exercises, the Comprehensive Capital Analysis and Review and the Dodd-Frank Act Stress Testing. See Hirtle and Lehnert (2014) for details on the US stress-testing framework.

²⁸See Landier and Thesmar (2014) for a discussion of the trade-offs associated to information disclosure in the context of systemic risk. Morgan, Peristiani, and Savino (2014), Ellahie (2013), and Petrella and Resti

3.2 A regulatory architecture to deal with systemic risk

The recognition of the importance of systemic risk has led to an important overhaul of the regulatory architecture, with increased coordination and centralization of regulatory powers at the global, regional, and national levels. Indeed, the segmentation of regulatory authorities typically leads to contagion risks building up, as a regulatory authority tends to neglect potential negative spillovers on the parts of the system it is not responsible for.

International coordination. It has long been recognized that international coordination of regulation is necessary to avoid a “race to the bottom” in regulatory standards (Dell’Ariccia and Marquez (2006)). The failure of the bank Herstatt in 1974 led to the creation of the BCBS precisely to solve coordination problems. Acharya (2003) points out that this might not be enough, as closure policies must also be coordinated. Failing this, no coordination at all may actually be better than coordination of regulation only, which leads to strategic behavior by bank supervisors.

The Financial Stability Board (FSB) was established in 2009 by the G20 to foster coordination among supervisors and ensure a level playing-field across jurisdictions. In addition, it acts as a global macro-prudential supervisor tasked with identifying systemic weaknesses in the global financial system and issuing recommendations to the relevant supervisory authorities. A concrete task of this new body is to issue the annual list of SIFIs, which are subject to additional capital requirements, between 1% and 3.5% of risk-weighted assets, depending on the bank’s systemic score (BCBS (2013b)).²⁹ Note that while being designated as systemically important means additional supervision and capital requirements, this may be desirable from the point of view of creditors, or may even be a sign of future bail-outs, so that the value of the bank can benefit from being designated as a SIFI.³⁰ This trade-off is empirically investigated by Moenninghoff, Ongena, and Wieandt (2015).

The United States. The supervisory architecture in the United States is heavily fragmented across multiple State and Federal supervisory agencies, in large part for historical reasons (see Komai and Richardson (2011)). Given this segmentation, supervisors have a

(2013) offer evidence on the impact of stress-test disclosure.

²⁹See Section 4.1 for a complete description of this framework. See <http://www.financialstabilityboard.org/> for the list of SIFIs.

³⁰As put by Douglas Flint, the chairman of HSBC: “I see it as a label that would attract customers, because such banks would be forced to hold more capital and be subject to more intense regulation”. See <http://www.guardian.co.uk/business/2011/nov/06/banks-disappointed-not-on-g-sifi-list>.

limited view of the overall system, as well as potential incentives to be too forbearant.³¹ The financial crisis led to a major restructuring of bank supervision, towards a more centralized architecture, with more powers for Federal agencies, in particular the Fed. For instance, the Securities and Exchange Commission ceased to be a banking supervisor when investment banks became bank holding companies in 2010. In the same year, the Dodd-Frank Wall Street Reform and Consumer Protection Act (Dodd-Frank Act) suppressed the Office of Thrift Supervision and allocated its responsibilities to the Office of the Comptroller of the Currency. The Fed has been tasked with conducting annual stress-tests of the banking system, thus becoming an important macro-prudential regulator. Symbolic of this shift towards a greater supervisory role, the Dodd-Frank Act created a second position of Vice Chairman of the Federal Reserve, dedicated to bank supervision.

In addition to this move towards centralization, the Dodd-Frank Act created the Financial Stability Oversight Council (FSOC), which comprises representatives of all the major US regulatory authorities. The FSOC is in charge of identifying and monitoring systemic risks in the United States, as well as eliminating expectations that American financial companies are too-big-to-fail and will be bailed out. In particular, the FSOC can designate non-bank financial firms as systemically important and require the Fed to supervise them, for instance asset management companies, financial market utilities (e.g. CCPs) or insurance companies.³²

The European Union and the Euro Area. The supervisory architecture in Europe is also fragmented, along national borders, and relies on a superposition of agencies at the national, EU, and euro area levels. However, the financial crisis accelerated a similar evolution as in the US towards more cooperation between agencies and centralization. The European Banking Authority (EBA) is in charge of ensuring harmonized supervision practices, the “single rulebook”, at the EU level, and can for instance deal with conflicts between different national supervisors in the EU. The European Systemic Risk Board (ESRB) was created in 2010 and is in charge of the macroprudential oversight of the EU financial system. In addition to the EBA, the European Securities and Markets Authority (ESMA) and the European Insurance and Occupational Pension Authority (EIOPA) were established in 2011 to deal with

³¹See for instance [Agarwal *et al.* \(2014\)](#) for recent evidence.

³²In January 2015, the insurance company Metlife filed on Federal court to oppose its designation as a SIFI by the FSOC. While the FSOC discussed whether large asset managers, such as Blackrock Inc. and Fidelity Investments, should be classified as SIFIs, it has since decided to focus on individual funds, rather than labeling firms.

the supervision of securities markets and insurance companies, respectively. EBA, ESMA and EIOPA, together with the ESRB and national supervisory authorities, form the so-called European System of Financial Supervision.

In parallel to this bottom-up approach trying to coordinate the actions of national supervisory agencies at the EU level, the euro crisis triggered the creation of powerful institutions at the euro area level in order to achieve a “European Banking Union”. Its first component is the Single Supervisory Mechanism (SSM), which makes the European Central Bank (ECB) responsible for banking supervision in the euro area, with a mandate to directly supervise the most significant banking groups (130 as of January 1st, 2015). The second pillar is the Single Resolution Mechanism, and the third one various funding arrangements: a Single Resolution Fund, deposit guarantee schemes, and a common backstop (credit line).

3.3 Challenges ahead

Despite undisputable progress, the regulation of systemic risk is still at an early stage and will probably undergo important changes in the years to come. Some particularly challenging issues still need to be addressed, such as discouraging herding and solving the too-big-to-fail problem.

It is also likely that many of the new tools introduced to deal with systemic risk will suffer from the Lucas critique. For instance, while loans with a low loan-to-value ratio are on average safer, it is not clear how banks will endogenously react to caps imposed on this measure. As many tools are new, their modeling and the empirical evaluation of their impact will be an important research topic going forward.

Additional regulatory tools and prudential requirements often come at the cost of reduced lending. Liquidity requirements for instance aim to decrease maturity mismatch in the banking sector and limit the need for banks to liquidate their assets, but financing illiquid projects with liquid liabilities is the core economic function of a bank. Instead of imposing more stringent requirements ex ante, some authors argue that it is more efficient to use ex post mechanisms. In [De Nicoló, Gamba, and Lucchetta \(2014\)](#) for instance, appropriate closure policies based on realized losses ex post are a more efficient tool than both capital and liquidity requirements. The reason for this result is that closure policies are conditional tools that are based on the observation of losses, whereas ex ante requirements will apply both in good and bad states of

the economy. [Jeanne and Korinek \(2013\)](#) study a similar trade-off between distortive ex ante measures and potentially costly ex post solutions in the context of macroprudential regulation.

The new regulatory tools are also often quite heavy-handed, as banks are directly discouraged or prevented from taking certain positions. This source-specific approach is followed for many different forms of systemic risk, which leads to less freedom for banks in making investment decisions. In addition, regulatory complexity increases, with the potential risk of the regulator being captured by some financial institutions ([Hakenes and Schnabel \(2015\)](#)). In contrast, several academic studies recommend following a global approach. For instance, [Korinek \(2012\)](#) proposes to use a Pigovian tax in order to make banks internalize the impact of their decisions on the system, without a heavier intervention on their actual decisions. A capital surcharge based on contributions to systemic risk can achieve a similar objective ([Acharya *et al.* \(2010a\)](#)).

The ambition of the microprudential approach of the Basel accords is to compute a measure of all the risks faced by a bank, and infer the minimum capital it needs to keep in order for public funds, and in particular the deposit insurer's, to be reasonably safe. Similarly, the holy grail of macroprudential regulation would be to compute a global measure of all the systemic externalities imposed by a bank, and charge the bank for the corresponding amount, thus correcting its incentives for systemic risk-taking. Replacing a host of case-by-case macroprudential tools by such a scheme will be possible only if sound empirical measures of systemic risk are available, and sufficiently reliable for day-to-day regulatory use.

4 Measurement

In order to operationalize the framework discussed in [Section 3](#), regulators need to quantify systemic risk. For a given source of risk, reliable measures would allow regulators to better calibrate targeted tools such as liquidity ratios. In addition, regulators are interested in identifying the institutions that contribute the most to the risk of the system at a given point in time (cross-section dimension), as well as monitoring how the risk of a given institution evolves over time (time series dimension). In this section, we review a large number of measures, classified in three types: the one proposed and implemented by the regulator, some structural measures that target a specific channel of transmission, and some global measures.

4.1 Regulatory approach

The scoring methodology developed by the BCBS for measuring systemic risk is both simple and intuitive. It aggregates information about five broad categories of systemic importance: size, cross-jurisdictional activity, interconnectedness, complexity, and lack of available substitutes for the services provided by the financial institution. In order not to favor any particular facet of systemic risk, the BCBS aims to give the same importance to each input (see BCBS (2013b), page 5). To meet this objective, each variable is divided by the aggregate amount for the variable summed across all sample banks. The overall score for each bank is then calculated by taking a simple average of its five category scores. This method is currently implemented by the FSB to identify the SIFIs and allocate them in different buckets.

While this ordinal approach permits to sort banks at a given point in time, its usefulness to monitor systemic risk over time is limited. Indeed, if the value of all risk inputs doubles for all banks, the scores remain the same, even though the system clearly became riskier.

Another unintended consequence of the regulatory approach is that the relative importance of the five categories may not be equal and that the resulting systemic risk score will be mechanically dominated by the most volatile categories. As a result, the scores, the ranking of banks, and in turn, their extra capital buffers, will be driven by a subset of variables only, which seems inconsistent with the original intention of the BCBS to give equal weights to each input. This bias is likely to have severe implications in practice. Indeed, BCBS (2013b) acknowledges that some variables have an abnormally high influence on the value of the systemic risk score. On page 6, the Committee states that they had to “apply a cap to the substitutability category score because this category has too high an impact on the final score”.

The truncation of some inputs is a crude and ad hoc way of reducing the influence of the most volatile variables. Instead, we suggest a slightly modified formula that prevents any category to play a dominant role in the computation of the score. Let each bank i , for $i = 1, \dots, N$, be characterized by K inputs or categories denoted X_{i1}, \dots, X_{iK} . The systemic risk score for bank i , denoted S_i , is then defined as a weighted sum of these K inputs:

$$S_i = \sum_{j=1}^K w_j \cdot x_{ij}, \quad (4)$$

where w_j corresponds to the weight (common to all banks) of input j in the systemic risk score, and $x_{ij} = \left(X_{ij} / \sum_{n=1}^N X_{nj} \right) \times 100$ corresponds to the relative value (in percentage) of input j for bank i . In order to give the same importance to each of these categories, the Committee considers an equally weighted index with $w_j = 1/K$. However, the equally-weighted scheme becomes problematic when the cross-sectional variances of the inputs are different. In such a case, a 10% increase of a given input does not represent the same signal if the factor has a variance of 1 or a variance of 100. One implication of this situation is that the ranking issued from the systemic risk score will be mainly driven by the most volatile categories.

One potential correction for the above-mentioned bias is to standardize by their volatility the variables that enter into the definition of the index. In that case, the systemic risk score becomes:

$$\tilde{S}_i = \sum_{j=1}^K w_j \times \frac{x_{ij}}{\sigma_j}, \quad (5)$$

where σ_j corresponds to the cross-sectional variance of input j . Note that the rest of the formula remains unchanged. In particular the weight of each input is still equal to $w_j = 1/K$.

4.2 Measures of systemic risk sources

Besides the regulatory approach, several promising methods have been proposed to measure the various sources of systemic risk identified in Section 2. In this section, we review those that are based on one particular source or channel of transmission of systemic risk.

Systemic risk-taking. To the best of our knowledge, [Lehar \(2005\)](#) was the first to empirically estimate the probability of a systemic crisis by focusing on correlation in banks' portfolios (following [Acharya \(2001\)](#)). This portfolio approach permits to estimate the probability of a simultaneous default of several banks, as well as the contribution of a given bank to the risk of the system.

[Blei and Ergashev \(2014\)](#) propose a measure of overlap in banks' assets, called the ACRISK measure (AC stands for asset commonality), which is based on a clustering analysis of quarterly data on bank portfolio weights. Their intuition is that the fragility of the system is higher in presence of overlapping positions across banks. Similarly, [Cai, Saunders, and Steffen \(2014\)](#) introduce another set of measures of interconnectedness based on the similarities (Euclidean distances) between two portfolios of syndicates loans.

The macro-finance literature proposes calibrated models of the economy that can produce a variety of systemic risk measures. For instance, [He and Krishnamurthy \(2014\)](#) develop a model in which the economy is either in normal states or in “systemic risk states”. It is used to compute the likelihood that the economy will be in a systemic crisis in the next quarter, both unconditionally and conditionally on stress scenarios. The interaction between the financial sector and the real economy can also be taken into account in more reduced-form measures of systemic risk. [De Nicoló and Lucchetta \(2011\)](#) study the joint dynamic of a systemic real risk indicator (defined as the VaR of the GDP) and a system financial risk measure (defined as the VaR of the return of a large portfolio of financial firms) with a factor-augmented vector autoregressive model. They show that their bivariate model predicts well the tail risk of the real activity for several countries and can be considered as a useful risk monitoring tool. Differently, the Default Intensity Model of [Giesecke and Kim \(2011\)](#) gives dynamic measures of the conditional probability of failure of a sufficiently large fraction of financial institutions. The estimators of the failure probability are based on a hazard model of correlated failure timing, which incorporates the influence on failure timing of macroeconomic and sector-specific risk factors, and past defaults.

Contagion. Early attempts to empirically study contagion within a network of financial institutions are [Upper and Worms \(2004\)](#) and [Elsinger, Lehar, and Summer \(2006\)](#). Using actual credit interlinkages among Austrian banks, they study how the insolvency of a single bank can contagiously be transmitted to other banks in a domino effect. [Upper \(2011\)](#) reviews the literature that simulates the second-round effects of a bank’s default on actual interbank systems. [Acemoglu, Ozdaglar, and Tahbaz-Salehi \(2015\)](#) introduce a notion of distance over the financial network that captures the propensity of a bank to be in distress when another bank is in distress. Using their measure, they can identify the institutions generating the maximal number of defaults following a shock to this particular institution, i.e., the SIFIs. Importantly, they show that as long as the frequency and the magnitude of the shocks affecting financial institutions are sufficiently small, a more equal distribution of interbank obligations enhances the stability of the system. However, beyond a certain point, more interconnections lead to more fragility. [Markose \(2012\)](#) applies a network analysis to the OTC derivatives markets and proposes a methodology to identify the most systemic financial institutions. In particular, she shows that 12 SIFIs account for 78% of all bilateral exposures and proposes a

Pigovian tax based on network centrality measures.

[Drehmann and Tarashev \(2011\)](#) develop two interconnection and contagion measures. The first one captures the ability of a given bank to propagate shocks across the financial system whereas the second one focuses on its vulnerability to shocks arising from other banks. These measures are based on Shapley values which permit to attribute system-wide risk to individual institutions. An important policy implication of this study is that focusing on exposures or contributions to systemic risk leads to different conclusions in terms of identifying SIFIs. [Gouriéroux, Héam, and Monfort \(2012\)](#) propose a theoretical model allowing for cross-holding in debt and equity in the balance sheets of banks, as well as common exposures to exogenous assets. This framework permits to identify the contagion effects of a shock that originates from outside the financial system. The authors propose a contagion measure based on the liquidation equilibrium that characterizes the number of non-defaulted banks, the total value of the banks, and the total value of the debt.³³ This structural approach raises some doubt about the usefulness of the identification of SIFIs: a firm may be systemic for a given shock, and not for another type of shock.

[Iyer and Peydró \(2011\)](#) show that bank runs and interbank linkages act as an important channel of contagion. Using as a natural experiment the failure of a large cooperative bank in India, they show that deposit withdrawal is larger when the interbank exposures to the failed bank are higher and that banks with weaker fundamentals are subject to a higher magnitude of contagion. Focusing on the days immediately following the collapse of Lehman Brothers, [Afonso, Kovner, and Schoar \(2011\)](#) show that interbank loans in the US became more sensitive to borrower characteristics, with higher spreads and lower borrowing for poorly performing large banks. However, they report no evidence of liquidity hoarding, in contrast with the predictions of the theoretical model of [Allen, Carletti, and Gale \(2009\)](#) and empirical findings from the UK interbank market ([Acharya and Merrouche \(2013\)](#)) and the Euro area ([Gabrieli and Georg \(2014\)](#)).

Amplification. [Greenwood, Landier, and Thesmar \(2015\)](#) develop a structural approach for systemic risk based on fire-sale spillovers. When a bank is forced to sell assets, it has a negative impact on their prices and as a consequence, a negative impact on other institutions

³³Unlike in [Greenwood, Landier, and Thesmar \(2015\)](#), the financial institutions do not modify their exposures after the shock.

with similar exposures, hence the contagion. Their framework explains how the distribution of leverage and risk exposures across banks contributes to systemic risk. It is based on the key assumption that banks target a given level of leverage, which implies asset sales when leverage is higher than the target. Bank vulnerability is defined as the impact on banks' equity of the deleveraging following a shock. The model is calibrated on European banks during the 2010-2011 sovereign debt crisis, as well as on US banks during the 2007-2009 financial crisis. The authors show that microprudential interventions, which target the solvency of individual banks, are always less effective than macroprudential policies which aim to minimize spillovers across financial firms. Furthermore, the different measures perform well to capture the pre-Lehman build-up in financial instability and the magnitude of the impact of Lehman's failure on the other banks. This result is confirmed by [Duarte and Eisenbach \(2015\)](#) who apply similar systemic risk measures to a panel of US commercial banks and broker-dealers over a longer time period. They show that the aggregate vulnerability measure starts increasing in 2004, long before many other systemic risk indicators, and reaches a peak in the fall of 2007.

In a related approach, [Brunnermeier, Gorton, and Krishnamurthy \(2014\)](#) present a liquidity measure, called Liquidity Mismatch Index (LMI), which corresponds to the difference between the "cash-equivalent" future values of the assets and of the liabilities of a bank. The "cash-equivalent" value is defined as the product of the current value of the asset or liability, multiplied by a liquidity weight (positive for assets, negative for liabilities) that depends on a given stress scenario. Then, the Value-at-Liquidity-Risk is defined as the say 5% worst losses and the Expected Liquidity Loss corresponds to the average of the liquidity losses beyond this threshold. The authors propose to use LMI to identify the most systemically important financial institutions. [Jobst \(2014\)](#) develops a structural model for liquidity risk that produces estimates for both the probability and the severity of joint liquidity events, where the latter are defined as situations in which banks jointly breach their NSFR ratios.

4.3 Global measures of systemic risk

A growing number of systemic risk measures are not targeted to a particular source of systemic risk or a channel of transmission. Instead, they take a global, multi-channel approach to systemic risk. The basic idea is that, if markets are efficient, a lot could be learned from the current market prices of the securities issued by financial institutions, or from derivatives

written on them. Contrary to measures based on data disclosed with a lag (accounting data) or on data not in the public domain (e.g. interconnectedness, substitutability), measures based on market data can be freely computed in real time. As such, they may be better able to detect sudden shifts in systemic risk regimes. However, a common pitfall of the measures reviewed in this section is that they are rarely theoretically grounded and generally do not permit to clearly identify the source of risk at play.

Four prominent examples of market-data based measures are the *Marginal Expected Shortfall* (MES) and the *Systemic Expected Shortfall* (SES) of Acharya *et al.* (2010a), the *Systemic Risk Measure* (SRISK) of Acharya, Engle, and Richardson (2012) and Brownlees and Engle (2015), and the *Delta Conditional Value-at-Risk* (ΔCoVaR) of Adrian and Brunnermeier (2014). Over the past five years, hundreds of research articles have discussed, implemented, and sometimes generalized, these systemic risk measures.³⁴ As shown in Figure 1, these systemic risk measures are the most central metrics in the systemic risk literature.

MES and SES. We consider N financial firms and denote r_{it} the stock return of firm i at time t . The market return is the value-weighted average of all individual returns, $r_{mt} = \sum_{i=1}^N w_{it}r_{it}$, where w_{it} denotes the relative market capitalization of firm i . The MES is the marginal contribution of an institution i to systemic risk, as measured by the Expected Shortfall (ES) of the system. Originally proposed by Acharya *et al.* (2010a), the MES was extended to a conditional version by Brownlees and Engle (2015). Formally, the conditional ES of the system at time t is defined as:

$$ES_{mt}(C) = \mathbb{E}_{t-1}(r_{mt} \mid r_{mt} < C) = \sum_{i=1}^N w_{it}\mathbb{E}_{t-1}(r_{it} \mid r_{mt} < C), \quad (6)$$

where C is a threshold. Then, the MES corresponds to the partial derivative of the system ES with respect to the weight of firm i in the economy (Scaillet (2004)):

$$MES_{it}(C) = \frac{\partial ES_{mt}(C)}{\partial w_{it}} = \mathbb{E}_{t-1}(r_{it} \mid r_{mt} < C). \quad (7)$$

MES measures the increase in the risk of the system (measured by the ES) induced by a marginal increase in the weight of firm i in the system. The SES extends the MES and corresponds to the amount a bank's equity drops below its target level (defined as a fraction

³⁴As of November 2015, these papers have been collectively cited more than 2,700 times (Google Scholar). For online computation of some of these systemic risk measures, see the Stern-NYU's V-Lab initiative at <http://vlab.stern.nyu.edu/welcome/risk/>.

k of assets) in case of a systemic crisis when aggregate capital is less than k times aggregate assets:

$$\frac{SES_{it}}{W_{it}} = k L_{it} - 1 - \mathbb{E}_{t-1} \left(r_{it} \mid \sum_{i=1}^N W_{it} < k \sum_{i=1}^N A_{it} \right), \quad (8)$$

where A_{it} denotes the total assets, W_{it} the market capitalization or market value of equity, and L_{it} the leverage, equal to A_{it}/W_{it} . Acharya *et al.* (2010a) show that the conditional expectation term can be expressed as an increasing linear function of the MES:

$$SES_{it} = (k L_{it} - 1 + \theta MES_{it} + \Delta_i) W_{it}, \quad (9)$$

where θ and Δ_i are constant terms.

SRISK. The SRISK measure proposed by Acharya, Engle, and Richardson (2012) and Brownlees and Engle (2015) extends the MES in order to take into account both the liabilities and the size of the financial institution. The SRISK corresponds to the expected capital shortfall of a given financial institution, conditional on a crisis affecting the whole financial system. In this perspective, the firms with the largest capital shortfall are assumed to be the greatest contributors to the crisis and are the institutions considered the most systemically risky. We follow Acharya, Engle, and Richardson (2012) and define the SRISK as:

$$SRISK_{it} = \max \left[0 ; \overbrace{k (D_{it} + (1 - LRMES_{it}) W_{it})}^{\text{Required Capital}} - \overbrace{(1 - LRMES_{it}) W_{it}}^{\text{Available Capital}} \right], \quad (10)$$

where k is the prudential capital ratio, D_{it} the book value of total liabilities, and LRMES is the long-run marginal expected shortfall, which corresponds to the expected drop in equity value the firm would experiment if the market were to fall by more than a given threshold within the next six months. As $L_{it} = (D_{it} + W_{it})/W_{it}$, SRISK becomes:

$$SRISK_{it} = \max [0 ; [k L_{it} - 1 + (1 - k) LRMES_{it}] W_{it}]. \quad (11)$$

We notice that SRISK increases with the leverage. Moreover, the expressions for SRISK and SES in equations (9) and (11) are almost identical.

The SRISK considers the interconnections of a firm with the rest of the system through the LRMES. Acharya, Engle, and Richardson (2012) propose to approximate it using the daily MES (defined for a threshold C equal to 2%) as $LRMES_{it} \simeq 1 - \exp(18 \times MES_{it})$.

This approximation represents the firm’s expected loss over a six-month horizon, obtained conditionally on the market falling by more than 40% within the next six months.

ΔCoVaR . Another popular systemic risk measure is the ΔCoVaR of [Adrian and Brunnermeier \(2014\)](#). $\text{CoVaR}_{it}^{m|\mathbb{C}(r_{it})}$ corresponds to the VaR of the market return obtained conditionally on some event $\mathbb{C}(r_{it})$ observed for firm i :

$$\Pr\left(r_{mt} \leq \text{CoVaR}_{it}^{m|\mathbb{C}(r_{it})} \mid \mathbb{C}(r_{it})\right) = \alpha. \quad (12)$$

The ΔCoVaR of firm i is then defined as the difference between the VaR of the financial system conditional on this particular firm being in financial distress and the VaR of the financial system conditional on firm i being in its median state. To define the distress of a financial institution, various definitions of $\mathbb{C}(r_{it})$ can be considered. Because they use a quantile regression approach, [Adrian and Brunnermeier \(2014\)](#) consider a situation in which the loss is precisely equal to its VaR:

$$\Delta\text{CoVaR}_{it}(\alpha) = \text{CoVaR}_{it}^{m|r_{it}=\text{VaR}_{it}(\alpha)} - \text{CoVaR}_{it}^{m|r_{it}=\text{Median}(r_{it})}. \quad (13)$$

This definition is generalized by [Girardi and Ergun \(2013\)](#), who define the financial distress of firm i as a situation in which the loss exceeds the VaR. We propose a comprehensive comparison of these measures in Section 5, along with an empirical application.

Other global measures. Many other papers aim to extract information about systemic risk from the joint distributions of banks’ extreme losses or returns. To our knowledge, the first paper to introduce a measure of aggregate banking-system risk is [Hartmann, Straetmans, and de Vries \(2007\)](#). Their tail- β captures the exposure of banks to extreme systematic shocks and can be estimated using multivariate extreme value theory.

[Billio *et al.* \(2012\)](#) use quarterly returns on hedge funds, banks, broker-dealers, and insurance companies to develop several measures of interconnectedness based on Granger causality tests and principal component analysis (see also the absorption ratio of [Kritzman *et al.* \(2011\)](#)). These measures provide direct estimates of the statistical connectivity within a system of financial institutions, and show that banks have played a predominant role in transmitting shocks compared to the other types of financial institutions. In the same vein, [Diebold and Yilmaz \(2014\)](#) model stock returns in a vector autoregressive framework to empirically estimate directional volatility connectedness measures among major US financial institutions.

Hautsch, Schaumburg, and Schienle (2015) define the systemic risk beta as the marginal effect of a firm’s VaR on the system’s VaR. In order to capture network spillover effects, the VaR of each firm is estimated by a quantile regression in which the set of regressors include other firms’ extreme losses.

Another approach consists in estimating implied joint default probabilities for financial institutions. Segoviano and Goodhart (2009) view the banking system as a portfolio of banks, for which individual default probabilities can be estimated from structural approaches or securities prices and, then aggregated at the system level using copulas. From the obtained multivariate distribution of defaults, they derive several banking distress measures. Alternatively, Giglio (2014) uses bonds and Credit Default Swap (CDS) spreads to measure the joint default of financial institutions. Huang, Zhou, and Zhu (2009) consider a hypothetical portfolio that consists of the total liabilities of all banks and compute an expected portfolio credit loss that exceeds a certain share of the banking sector’s total liabilities. This expected loss also depends on banks’ CDS and corresponds to the actuarial premium of an insurance policy that would protect against the distress of this portfolio, hence its name Distress Insurance Premium (DIP). Oh and Patton (2015) compute a joint probability of distress based on a dynamic copula model of CDS spreads. They show that idiosyncratic default risk has been reduced since 2009 in the US whereas systemic risk increased during the post-crisis period. Finally, Kelly, Lustig, and van Nieuwerburgh (2012) exploit option prices to show the existence of a collective government guarantee for the US financial sector.

5 Systemic or systematic?

In this section, we derive new results on several prominent risk measures within a unified theoretical framework. This common framework allows to better understand their fundamental differences, and in particular, the additional information that these systemic risk metrics are able to provide over and above systematic market risk measures such as beta or correlation.

5.1 Common theoretical framework

Consider a bivariate GARCH process for the vector of market and firm demeaned returns $r'_t = (r_{mt} \ r_{it})$, such that:

$$r_t = H_t^{1/2} \nu_t, \tag{14}$$

where the innovation $\nu'_t = (\varepsilon_{mt} \ \xi_{it})$ is i.i.d. with $\mathbb{E}(\nu_t) = 0$ and $\mathbb{E}(\nu_t \nu'_t) = I_2$, a two-by-two identity matrix, and the conditional variance-covariance matrix H_t is defined as:

$$H_t = \begin{pmatrix} \sigma_{mt}^2 & \sigma_{it} \sigma_{mt} \rho_{it} \\ \sigma_{it} \sigma_{mt} \rho_{it} & \sigma_{it}^2 \end{pmatrix}, \quad (15)$$

where σ_{it} and σ_{mt} denote the conditional standard deviations and ρ_{it} the conditional correlation. For simplicity, we assume that the innovations ε_{mt} and ξ_{it} are independently distributed at time t , which means that the time-varying conditional correlation ρ_{it} fully captures the dependence between the firm and market returns.³⁵

Under these assumptions, we can show that the MES of a given financial institution i is proportional to its systematic risk, as measured by its time-varying beta. The proportionality coefficient is the expected shortfall of the market:

$$MES_{it}(\alpha) = \beta_{it} ES_{mt}(\alpha), \quad (16)$$

where $ES_{mt}(\alpha) = \mathbb{E}_{t-1}(r_{mt} \mid r_{mt} < VaR_{mt}(\alpha))$ is the expected shortfall of the market and $\beta_{it} = \rho_{it}\sigma_{it}/\sigma_{mt}$ the time-varying beta of firm i . The proof of Equation (16) is in [Benoit et al. \(2013\)](#) (Appendix A) and in [Brownlees and Engle \(2015\)](#). This result has two main implications. First, on a given date, the systemic risk ranking of financial institutions based on MES is strictly equivalent to the ranking that would be produced by sorting them according to their betas. Indeed, since the system expected shortfall is not firm-specific, a firm's estimated systemic importance simply increases with its market beta. Second, for a given financial institution, the time profile of its systemic risk measured by its MES may be different from the evolution of its systematic risk measured by its conditional beta. Since the market ES may not be constant over time, forecasting the systematic risk of firm i may not be sufficient to forecast the future evolution of its contribution to systemic risk.

As SRISK is a function of the MES, SRISK can be expressed as a function of the beta, leverage, and market capitalization of the financial institution:

$$SRISK_{it} \simeq \max[0; [k(L_{it} - 1) + (1 - k) \exp(18 \times \beta_{it} \times ES_{mt}(\alpha))] W_{it}]. \quad (17)$$

SRISK is an increasing function of the systematic risk, as measured by the conditional beta since $ES_{mt}(\alpha)$ is typically a negative number and the prudential capital ratio k is smaller than

³⁵We will relax this assumption in the empirical analysis in Section 5.2.

one. However, unlike with MES, systemic-risk rankings based on SRISK are not equivalent to rankings based on betas. SRISK-based rankings also depend on the leverage and on the market capitalization of the financial institution. Accounting for market capitalization and liabilities in the definition of the systemic risk measure tends to increase the systemic risk score of large firms. This result is in line with the too-big-to-fail paradigm, whereas the MES tends to be naturally driven by interconnected institutions (through the beta), which is more in line with the too-interconnected-to-fail paradigm (Markose, Giansante, and Shaghghi (2012)). In that sense, the SRISK can be viewed as a compromise between both paradigms.³⁶

Within this framework, it is also possible to express ΔCoVaR , defined for the conditioning event $r_{it} = \text{VaR}_{it}(\alpha)$, as a function of the conditional correlations, volatilities, and VaR. Given Equations (14) and (15), we can show that the ΔCoVaR of a given financial institution i is proportional to its tail risk, as measured by its VaR. The proportionality coefficient corresponds to the linear projection coefficient of the market return on the firm return.

$$\Delta\text{CoVaR}_{it}(\alpha) = \gamma_{it} [\text{VaR}_{it}(\alpha) - \text{VaR}_{it}(0.5)], \quad (18)$$

where $\gamma_{it} = \rho_{it}\sigma_{mt}/\sigma_{it}$. If the marginal distribution of the return is symmetric around zero, ΔCoVaR is:

$$\Delta\text{CoVaR}_{it}(\alpha) = \gamma_{it} \text{VaR}_{it}(\alpha). \quad (19)$$

The proof of Equation (19) is in Benoit *et al.* (2013) (Appendix B).³⁷ The fact that the proportionality coefficient between ΔCoVaR and VaR is firm-specific implies that the most risky institutions (in terms of VaR) are not necessarily the most *systemically* risky ones (in terms of ΔCoVaR). In that sense, ΔCoVaR is not equivalent to VaR in the cross-section, as already pointed out by Adrian and Brunnermeier (2014) in their Figure 1. However, for a given institution i , when the variance-covariance matrix is constant or when ΔCoVaR is estimated by quantile regression as in Adrian and Brunnermeier (2014), the coefficient γ_{it} is constant over time. In that case, ΔCoVaR becomes proportional to VaR and, as a consequence, forecasting the systemic contribution of a firm is equivalent to forecasting its tail risk in isolation.

³⁶Engle, Jondeau, and Rockinger (2015) use SRISK divided by the GDP of a country to sort domestic banks and identify domestic systemically important banks.

³⁷Under the normality assumption, Adrian and Brunnermeier (2014) also show that ΔCoVaR is a function of VaR: $\Delta\text{CoVaR}_{it}(\alpha) = \rho_{it}\sigma_{mt}\Phi^{-1}(\alpha)$ or equivalently $\gamma_{it}\sigma_{it}\Phi^{-1}(\alpha)$, where $\sigma_{it}\Phi^{-1}(\alpha)$ denotes the VaR(α) of the firm.

5.2 Empirical illustration

The theoretical results derived in Section 5.1 have been derived within a specific common framework. However, in practice, the dependence between financial asset returns may be richer (i.e., not linear) and thus our results may not hold in real financial markets. For this reason, we now relax the assumptions made in Equations (14) and (15) for asset returns. In our empirical analysis, we implement the same estimation methods as in the original articles presenting the MES, SRISK, and ΔCoVaR , and we use the same sample as in Acharya, Pedersen, Philippon, and Richardson (2010a). This sample contains all US financial firms with a market capitalization greater than \$5 billion as of end of June 2007. For our sample period, January 3, 2000 - December 31, 2010, we extract daily firm stock returns, value-weighted market index returns, number of shares outstanding, and daily closing prices from CRSP. Quarterly book values of total liabilities are from COMPUSTAT. Following Brownlees and Engle (2015), we estimate the MES and SRISK using a GARCH-DCC model. We use a coefficient α of 5%, and the threshold C is set equal to the unconditional market daily VaR at 5%, which is equal to 2.52% in our sample. The ΔCoVaR is estimated with a quantile regression as proposed by Adrian and Brunnermeier (2014).

We first investigate the relationship between MES and beta in Figure 3. This scatter plot compares the average MES, $\overline{MES}_i(\alpha) = T^{-1} \sum_{t=1}^T |MES_{it}(\alpha)|$, to the average beta, $\bar{\beta}_i = T^{-1} \sum_{t=1}^T \beta_{it}$, for the 61 firms that have been continuously traded during our sample period. This plot confirms the strong relationship between MES (y -axis) and firm beta (x -axis). In line with Equation (16), the OLS estimated slope coefficient (0.0248) is extremely close to the unconditional ES of the market at 5%, 0.0252 or 2.52%.³⁸ The main implication of this result is that systemic risk rankings of financial institutions based on their MES tend to mirror rankings obtained by sorting firms on betas.

Should one worry about the fact that MES and beta give similar rankings? We think that this is a serious concern for the following reasons. First, if beta is believed to be a good proxy for systemic risk, why not rank firms on betas in the first place? Second, this leads to confusion between *systemic risk* and *systematic risk* (market risk); the latter being already accounted for in the banking regulation since the 1996 Amendment of the Basel Accord as regulatory

³⁸Similar results (not reported) are obtained when we consider constant betas rather than conditional betas, or when we consider the firm's MES and beta at a given point in time rather than averages.

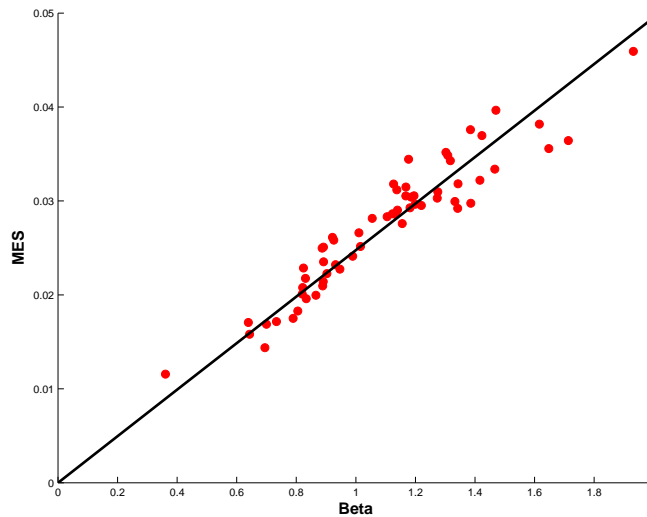

Figure 3: Systemic Risk or Systematic Risk? The scatter plot shows the strong cross-sectional link between the time-series average of the MES at 5% estimated for each institution (y -axis) and its beta (x -axis). The beta corresponds to the average of the time-varying beta β_{it} . Each point represents a financial institution and the solid line is the OLS regression line with no constant. The estimation period is from 01/03/2000 to 12/31/2010.

capital depends on the banks' market risk VaR. Third, betas tend to increase during economic downturns, which makes MES procyclical. Note that the connection between systemic risk and systematic risk is less tight for SRISK, as it also reflects the leverage and the market capitalization.

As already pointed out by [Adrian and Brunnermeier \(2014\)](#) in their Figure 1, there is only a weak relationship between an institution's risk in isolation, measured by its VaR, and its contribution to systemic risk, measured by its ΔCoVaR . In that sense, ΔCoVaR is definitely not VaR. However, the latter conclusion is more questionable in the time series. Figure 4 compares the dynamics of the ΔCoVaR and VaR of Bank of America over the entire sample period. We see that the two lines match almost perfectly, as predicted by our theoretical analysis in Section 5.1. Indeed, with quantile regression, ΔCoVaR is strictly proportional to VaR ($\gamma_{it} = \gamma_i$). This result is robust to the estimation method used. When the ΔCoVaR is estimated with a DCC model (not reported), the correlation is not one anymore but remains high.

As this brief overview has illustrated, there remains a gap between the two main approaches for measuring systemic risk. The "source-specific approach" highlights a number of

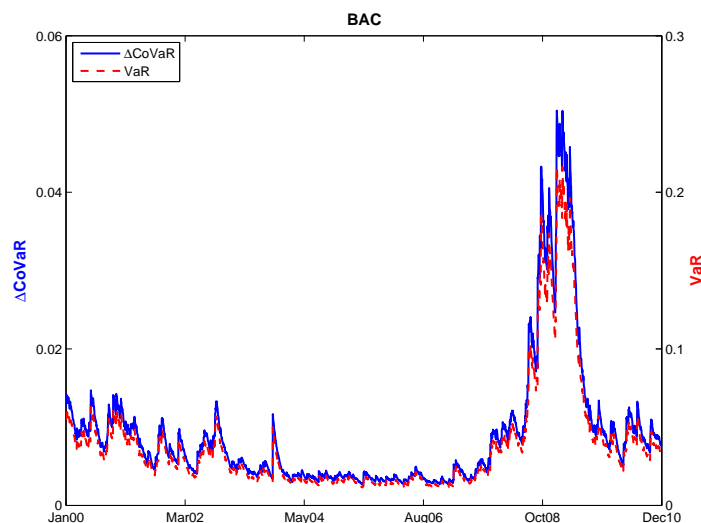

Figure 4: CoVaR is Equivalent to VaR in Time Series. The figure displays the ΔCoVaR (solid line, left y-axis) and the 5%-VaR (dashed line, right y-axis) of Bank of America (BAC).

mechanisms, which lead to a host of different risk measures and regulations. Despite many appealing properties, even the best global measures cannot encompass this variety of systemic risk sources. Indeed, a limited number of variables seem sufficient to capture their variation in the cross section (MES and SRISK) or in the time series dimension (ΔCoVaR). Regulatory authorities, with their preferred access to proprietary data, keep using their own approach to produce global measures of systemic risk, with the shortcomings pointed out in Section 4.1.

6 Validation

As we have seen in the previous two sections, there is an impressive variety of competing systemic risk measures. Regulators and other end-users of these measures thus need guidance on how to select the ones most adapted to their objectives. To this end, we compared some of the most popular measures in Section 5. We review in this section other recent attempts to contrast existing measures, following two approaches: an ex ante comparison of risk measures based on their mathematical properties, and an ex post approach based on their empirical performance.

6.1 Theoretical analysis of risk measures

As of yet, only few papers analyze the desirable properties that a sound systemic risk measure should comply with. Following the coherent risk approach of Artzner *et al.* (1999), Chen, Iyengar, and Moallemi (2013) define an axiomatic framework for systemic risk measures. Their analysis is based on the joint distribution of outcomes across all financial firms and all states of nature. In this framework, a systemic risk measure is a function from the space of firms and outcomes to \mathbb{R} . This function must satisfy the main conditions that define any coherent risk measure, namely the monotonicity, positive homogeneity, and outcome convexity axioms.³⁹ However, a systemic risk measure must also satisfy an additional preference consistency axiom. This axiom states that the risk measure has to reflect the preference of the regulator on the cross-sectional profile of losses across firms and the distribution of the aggregate outcomes across states. Brunnermeier and Oehmke (2013a) also require a measure to satisfy the clone property: if a financial institution is split into several equal parts, the total systemic risk does not change, since risk is also equally divided. When complying with this property, a measure captures systemic risk originating from small institutions that behave in a correlated way.

A good risk measure should also allow regulators to impose a firm-specific capital surcharge in an economically consistent way. Gouriéroux and Monfort (2013) propose a set of axioms (decentralization, additivity, and risk ordering) for dividing an aggregate systemic risk measure into individual contributions. In particular, they show that the Shapley value does not satisfy these axioms, while the Euler equation does. Brunnermeier and Cheridito (2014) introduce SystRisk which is a measure of total systemic risk satisfying the allocation and clone properties. Furthermore, their measure includes a tolerance parameter that can be adjusted over time to implement countercyclical regulation, especially when volatility is low.

These different approaches assume that the risk measure is correctly estimated. Given the variety of risk measures that have been proposed and data limitations, any single systemic risk measure will necessarily be fraught with uncertainty. Hansen (2013) discusses the challenge of measuring this uncertainty and designing regulatory approaches that are robust to this problem.

³⁹The *monotonicity* condition reflects that if one firm has greater losses in every scenario than another, it is less preferred. The positive *homogeneity* implies that the risk measure increases in proportion to the scale of losses. The *outcome convexity* condition is the basis of the diversification principle: the risk of a firm diversified between two outcomes is lower than the weighted risk that corresponds to these two outcomes.

6.2 Empirical assessment of risk measures

Empirical validation is a key requirement for any systemic risk measure to become an industry standard. There is no consensus at the moment, and several approaches have been followed in the academic literature. [Brownlees and Engle \(2015\)](#) show that banks with higher SRISK before the financial crisis were more likely to be bailed out by the government and to receive capital injections from the Federal Reserve. Alternative approaches include testing whether firms with high systemic risk scores are more likely to become insolvent ([Wu and Zhao \(2014\)](#)), to suffer the highest financial losses ([Idier, Lamé, and Mésonnier \(2014\)](#)), or to have the most negative stock returns ([Acharya, Engle, and Richardson \(2012\)](#)) in a financial crisis.

For firm-level measures, one can compare the empirical ranking obtained with a given measure with the one computed by the FSB, which is based on confidential bank supervisory data ([Engle, Jondeau, and Rockinger \(2015\)](#)). [Cai, Saunders, and Steffen \(2014\)](#) find a positive correlation between interconnectedness (measured by being member of the same loan syndicate) and standard bank-level systemic risk measures including SRISK, CoVaR, and DIP, during recessions. Another strategy followed by [Duarte and Eisenbach \(2015\)](#) is to show that their risk measure Granger-causes most other systemic risk measures. In the same vein, [Rodríguez-Moreno and Peña \(2013\)](#) compare several market-based systemic risk measure and rank these measures using three criteria to argue that systemic risk measures based on CDSs outperform measures based on interbank interest rates or stock market prices.

For systemic risk measures defined at the system level, one can test whether a high systemic risk score can be seen as an early warning signal and is positively and significantly associated with future systemic risk events. [Allen, Bali, and Tang \(2012\)](#) show that high levels of systemic risk in the banking sector, as captured by their CATFIN measure, impact the macroeconomy through aggregate lending activity. They show that CATFIN can forecast macroeconomic downturns approximately six months before they occur. Similarly, [Giglio, Kelly, and Pruitt \(2015\)](#) test whether existing systemic risk measures are able to predict macroeconomic downturns using long times series (starting in the 1920's) and international data.

7 Conclusion

Despite the breathtaking pace at which research on systemic risk has progressed, much remains to be done. This survey can serve as a catalyst for future developments in at least three areas which we list below.

Measurement is a key issue for policymakers, who are looking for tools to monitor the building up of risks and quantify the negative externalities imposed by systemic institutions on the whole system. Many methodologies are now available to identify different sources of systemic risk and will probably be developed into full fledged regulatory tools in the near future. What is less clear is how to link the measures produced by these tools to regulatory interventions: observing that a bank has become more central in the interbank market does not translate directly into a clear policy response. More structural models, linking risk estimates to well-defined policy objectives and available tools, would be useful to regulators.

The economic mechanisms leading to systemic risk have been researched for even longer, so that we now have a good understanding of where the risks can lie. However, the issue of how to optimally regulate banks and correct the different market failures leading to systemic risk has been less investigated. In particular, many macroprudential tools are quite new and the extent of their impact is not fully understood yet, neither theoretically nor empirically. There will be an important learning-by-doing process as regulators will increasingly make use of the new toolbox, giving empiricists experiments to analyze and theorists stylized facts to explain.

The quest for a global risk measure that encompasses different sources of systemic risk, and yet produces a single metric that can directly be used for regulation, is still ongoing. However, we have reasons to remain optimistic as more data are becoming available, with better quality, higher frequency, and wider scope (see the G20 Data Gaps Initiative, [Cerutti, Claessens, and McGuire \(2014\)](#)). Given the very nature of systemic risk, future risk measures should combine various sources of information, including balance-sheet data, proprietary data on positions, and market data, as well as regulators' assessments of banks' interconnectedness and riskiness. In the future, such an approach could complement or eventually replace a host of technical macroprudential tools by a simple systemic risk tax or capital surcharge aligning systemic banks' interests with the social optimum. This would have significant benefits in

terms of efficiency and simplicity.

References

- ACEMOGLU, D., A. OZDAGLAR, AND A. TAHBAZ-SALEHI (2015): “Systemic Risk and Stability in Financial Networks,” *The American Economic Review*, 105(2), 564–608. 14, 30
- ACHARYA, V. V. (2001): “A Theory of Systemic Risk and Design of Prudential Bank Regulation, Unabridged version,” Working paper. 2, 3, 29
- (2003): “Is the International Convergence of Capital Adequacy Regulation Desirable?,” *The Journal of Finance*, 58(6), 2745–2782. 24
- (2009): “A theory of systemic risk and design of prudential bank regulation,” *Journal of Financial Stability*, 5(3), 224–255. 9
- ACHARYA, V. V., AND A. BISIN (2014): “Counterparty risk externality: Centralized versus over-the-counter markets,” *Journal of Economic Theory*, 149(C), 153–182. 15
- ACHARYA, V. V., T. COOLEY, M. RICHARDSON, AND I. WALTER (2010): “Manufacturing Tail Risk: A Perspective on the Financial Crisis of 2007-2009,” *Foundations and Trends in Finance*, 4(4), 247–325. 11
- ACHARYA, V. V., R. ENGLE, AND M. RICHARDSON (2012): “Capital Shortfall: A New Approach to Ranking and Regulating Systemic Risks,” *The American Economic Review*, 102(3), 59–64. 33, 34, 43
- ACHARYA, V. V., D. GALE, AND T. YORULMAZER (2011): “Rollover Risk and Market Freezes,” *The Journal of Finance*, 66(4), 1177–1209. 17
- ACHARYA, V. V., AND O. MERROUCHE (2013): “Precautionary Hoarding of Liquidity and Interbank Markets: Evidence from the Subprime Crisis,” *Review of Finance*, 17(1), 107–160. 3, 31
- ACHARYA, V. V., AND H. NAQVI (2012): “The seeds of a crisis: A theory of bank liquidity and risk taking over the business cycle,” *Journal of Financial Economics*, 106(2), 349–366. 13
- ACHARYA, V. V., AND T. ÖNCÜ (2013): “A Proposal for the Resolution of Systemically Important Assets and Liabilities: The Case of the Repo Market,” *International Journal of Central Banking*, 9(s1), 291–349. 21
- ACHARYA, V. V., L. H. PEDERSEN, T. PHILIPPON, AND M. RICHARDSON (2010a): “Measuring systemic risk,” Working paper. 3, 9, 39
- ACHARYA, V. V., L. H. PEDERSEN, T. PHILIPPON, AND M. RICHARDSON (2010b): “Taxing Systemic Risk,” in *Regulating Wall Street: The Dodd-Frank Act and the New Architecture of Global Finance*, ed. by V. Acharya, T. Cooley, M. Richardson, and Walter, pp. 121–142. Princeton University Press. 27, 33, 34
- ACHARYA, V. V., AND A. THAKOR (2015): “The dark side of liquidity creation: leverage and systemic risk,” Working paper. 15

- ACHARYA, V. V., AND T. YORULMAZER (2008a): “Cash-in-the-Market Pricing and Optimal Resolution of Bank Failures,” *Review of Financial Studies*, 21(6), 2705–2742. 10
- (2008b): “Information Contagion and Bank Herding,” *Journal of Money, Credit and Banking*, 40(1), 215–231. 10
- ADRIAN, T., AND M. BRUNNERMEIER (2014): “CoVaR,” Working paper. 3, 33, 35, 38, 39, 40
- ADRIAN, T., AND H. S. SHIN (2014): “Procyclical Leverage and Value-at-Risk,” *Review of Financial Studies*, 27(2), 373–403. 12
- AFONSO, G., A. KOVNER, AND A. SCHOAR (2011): “Stressed, Not Frozen: The Federal Funds Market in the Financial Crisis,” *The Journal of Finance*, 66(4), 1109–1139. 3, 31
- AFONSO, G., AND H. S. SHIN (2011): “Precautionary Demand and Liquidity in Payment Systems,” *Journal of Money, Credit & Banking*, 43(7), 589–619. 15
- AGARWAL, S., D. LUCCA, A. SERU, AND F. TREBBI (2014): “Inconsistent Regulators: Evidence from Banking,” *Quarterly Journal of Economics*, 129(2), 889–938. 25
- AGHION, P., P. BOLTON, AND M. DEWATRIPONT (2000): “Contagious bank failures in a free banking system,” *European Economic Review*, 44(4-6), 713–718. 15
- AIYAR, S., C. W. CALOMIRIS, AND T. WIELADEK (2014): “Does Macro-Prudential Regulation Leak? Evidence from a UK Policy Experiment,” *Journal of Money, Credit and Banking*, 46(s1), 181–214. 3, 20
- ALLEN, F., AND A. BABUS (2009): “Networks in Finance,” in *Network-based Strategies and Competencies*, ed. by P. Kleindorfer, and J. Wind, pp. 367–382. Wharton School Publishing. 14
- ALLEN, F., A. BABUS, AND E. CARLETTI (2012): “Asset commonality, debt maturity and systemic risk,” *Journal of Financial Economics*, 104(3), 519–534. 14
- ALLEN, F., AND E. CARLETTI (2013): “Systemic risk from real estate and macro-prudential regulation,” *International Journal of Banking, Accounting and Finance*, 5(1/2), 28–48. 13
- ALLEN, F., E. CARLETTI, AND D. GALE (2009): “Interbank market liquidity and central bank intervention,” *Journal of Monetary Economics*, 56(5), 639–652. 31
- ALLEN, F., E. CARLETTI, I. GOLDSTEIN, AND A. LEONELLO (2015): “Government guarantees and financial stability,” CEPR Discussion Paper Series 10560. 22
- ALLEN, F., AND D. GALE (1994): “Limited Market Participation and Volatility of Asset Prices,” *The American Economic Review*, 84(4), 933–955. 16
- (2000a): “Bubbles and Crises,” *The Economic Journal*, 110(460), 236–255. 13
- (2000b): “Financial Contagion,” *Journal of Political Economy*, 108(1), 1–33. 2, 3, 13
- (2004a): “Financial Fragility, Liquidity, and Asset Prices,” *Journal of the European Economic Association*, 2(6), 1015–1048. 16

- (2004b): “Financial Intermediaries and Markets,” *Econometrica*, 72(4), 1023–1061. 16
- (2007): “Systemic Risk and Regulation,” in *The Risks of Financial Institutions*, NBER Chapters, pp. 341–376. National Bureau of Economic Research. 21
- ALLEN, L., T. G. BALI, AND Y. TANG (2012): “Does Systemic Risk in the Financial Sector Predict Future Economic Downturns?,” *Review of Financial Studies*, 25(10), 3000–3036. 43
- ALLEN, W. A., AND R. MOESSNER (2010): “Central bank co-operation and international liquidity in the financial crisis of 2008-9,” Working Paper 310, Bank for International Settlements. 11
- ALTER, A., B. R. CRAIG, AND P. RAUPACH (2015): “Centrality-Based Capital Allocations,” *International Journal of Central Banking*, 11(3), 329–377. 21
- ANAND, K., P. GAI, S. KAPADIA, S. BRENNAN, AND M. WILLISON (2013): “A network model of financial system resilience,” *Journal of Economic Behavior & Organization*, 85(C), 219–235. 14
- ARORA, S., B. BARAK, M. BRUNNERMEIER, AND R. GE (2009): “Computational Complexity and Information Asymmetry in Financial Products,” Working paper. 18
- ARTZNER, P., F. DELBAEN, J.-M. EBER, AND D. HEATH (1999): “Coherent measures of risk,” *Mathematical Finance*, 9(3), 203–228. 42
- BABUS, A. (2015): “The Formation of Financial Networks,” *RAND Journal of Economics*, Forthcoming. 14
- BABUS, A., AND T.-W. HU (2015): “Endogenous Intermediation in Over-the-Counter Markets,” Working paper, Federal Reserve Bank of Chicago. 14
- BABUS, A., AND P. KONDOR (2013): “Trading and Information Diffusion in Over-the-Counter Markets,” Working paper, Federal Reserve Bank of Chicago. 14
- BAE, K.-H., G. A. KAROLYI, AND R. M. STULZ (2003): “A New Approach to Measuring Financial Contagion,” *Review of Financial Studies*, 16(3), 717–763. 3, 16
- BANERJEE, R. N., AND H. MIO (2014): “The Impact of Liquidity Regulation on Banks,” BIS Working Papers 470, Bank for International Settlements. 3
- BASEL COMMITTEE ON BANKING SUPERVISION (1991): “Measuring and controlling large credit exposures,” Report. 21
- (2011): “Basel III: A Global Framework for more Resilient Banks and Banking Systems,” Report. 19
- (2013a): “Basel III: The Liquidity Coverage Ratio and Liquidity Risk Monitoring Tools,” Report. 20
- (2013b): “Global Systemically Important Banks: Updated Assessment Methodology and the Higher Loss Absorbency Requirement,” Report. 24, 28

- (2014a): “Basel III: Leverage Ratio Framework and Disclosure Requirements,” Report. 19
- (2014b): “Basel III: The Net Stable Funding Ratio,” Report. 20
- (2014c): “Supervisory framework for measuring and controlling large exposures - final standard,” Report. 21
- BASEL COMMITTEE ON BANKING SUPERVISION AND BOARD OF THE INTERNATIONAL ORGANIZATION OF SECURITIES COMMISSIONS (2013): “Margin Requirements for non-centrally cleared derivatives,” Report. 22
- BENOIT, S., G. COLLETAZ, C. HURLIN, AND C. PÉRIGNON (2013): “A Theoretical and Empirical Comparison of Systemic Risk Measures,” Working paper. 37, 38
- BENOIT, S., C. HURLIN, AND C. PÉRIGNON (2015): “Implied Risk Exposures,” *Review of Finance*, Forthcoming. 12
- BERNANKE, B., AND M. GERTLER (1989): “Agency Costs, Net Worth, and Business Fluctuations,” *The American Economic Review*, 79(1), 14–31. 2, 3, 12
- BERNANKE, B. S. (2013): “Stress Testing Banks: What Have We Learned?,” Remarks by Chairman Ben S. Bernanke at the “Maintaining Financial Stability: Holding a Tiger by the Tail” Federal Reserve Bank of Atlanta conference. 21
- BERNARDO, A. E., AND I. WELCH (2004): “Liquidity and Financial Market Runs,” *The Quarterly Journal of Economics*, 119(1), 135–158. 18
- BHATTACHARYA, S., AND D. GALE (1987): “Preference shocks, liquidity and central bank policy,” in *New Approaches to Monetary Economics*, ed. by W. Barnett, and K. Singleton, pp. 69–88. Cambridge University Press. 3, 11
- BHATTACHARYA, S., C. GOODHART, D. TSOMOCOS, AND A. VARDOULAKIS (2011): “Minsky’s Financial Instability Hypothesis and the Leverage Cycle,” Working paper. 12
- BIAIS, B., F. HEIDER, AND M. HOEROVA (2015): “Risk-sharing or risk-taking? An incentive theory of counterparty risk, clearing and margins,” *The Journal of Finance*, Forthcoming. 15
- BIAIS, B., T. MARIOTTI, J.-C. ROCHET, AND S. VILLENEUVE (2010): “Large Risks, Limited Liability, and Dynamic Moral Hazard,” *Econometrica*, 78(1), 73–118. 12
- BIANCHI, J., AND E. G. MENDOZA (2015): “Optimal Time-Consistent Macroprudential Policy,” Working Paper 19704, National Bureau of Economic Research. 20
- BILLIO, M., M. GETMANSKY, A. W. LO, AND L. PELIZZON (2012): “Econometric measures of connectedness and systemic risk in the finance and insurance sectors,” *Journal of Financial Economics*, 104(3), 535–559. 3, 35
- BISIAS, D., M. FLOOD, A. W. LO, AND S. VALAVANIS (2012): “A Survey of Systemic Risk Analytics,” *Annual Review of Financial Economics*, 4(1), 255–296. 7

- BLEI, S., AND B. ERGASHEV (2014): “Asset commonality and systemic risk among large banks in the United States,” Working paper. [3](#), [29](#)
- BOISSAY, F., F. COLLARD, AND F. SMETS (2015): “Booms and systemic banking crises,” *Journal of Political Economy*, Forthcoming. [12](#)
- BORIO, C. (2003): “Towards a macroprudential framework for financial supervision and regulation?,” Working Paper 128, Bank for International Settlements. [2](#)
- BOSS, M., H. ELSINGER, M. SUMMER, AND S. THURNER (2004): “Network topology of the interbank market,” *Quantitative Finance*, 4(6), 677–684. [14](#)
- BOUVARD, M., P. CHAIGNEAU, AND A. DE MOTTA (2015): “Transparency in the Financial System: Rollover Risk and Crises,” *The Journal of Finance*, 70(4), 1805–1837. [23](#)
- BOYSON, N. M., C. W. STAHEL, AND R. M. STULZ (2010): “Hedge Fund Contagion and Liquidity Shocks,” *The Journal of Finance*, 65(5), 1789–1816. [17](#)
- BROWNLEES, T. C., AND R. F. ENGLE (2015): “SRISK: A conditional capital shortfall index for systemic risk measurement,” Working paper. [3](#), [33](#), [34](#), [37](#), [39](#), [43](#)
- BRUNNERMEIER, M., G. GORTON, AND A. KRISHNAMURTHY (2014): “Liquidity Mismatch Measurement,” in *Risk Topography: Systemic Risk and Macro Modeling*, NBER Chapters, pp. 99–112. National Bureau of Economic Research. [3](#), [32](#)
- BRUNNERMEIER, M. K., AND P. CHERIDITO (2014): “Measuring and allocating systemic risk,” Working paper. [42](#)
- BRUNNERMEIER, M. K., T. M. EISENBACH, AND Y. SANNIKOV (2013): “Macroeconomics with Financial Frictions: A Survey,” in *Advances in Economics and Econometrics, Tenth World Congress of the Econometric Society, Vol. 2*, pp. 3–96. Cambridge University Press, New York. [12](#)
- BRUNNERMEIER, M. K., AND M. OEHMKE (2013a): “Bubbles, financial crises, and systemic risk,” in *Handbook of the Economics of Finance*, ed. by M. H. George M. Constantinides, and R. M. Stulz, pp. 1221–1288. Elsevier. [13](#), [42](#)
- BRUNNERMEIER, M. K., AND M. OEHMKE (2013b): “The Maturity Rat Race,” *The Journal of Finance*, 68(2), 483–521. [3](#), [11](#), [18](#)
- BRUNNERMEIER, M. K., AND L. H. PEDERSEN (2009): “Market Liquidity and Funding Liquidity,” *Review of Financial Studies*, 22(6), 2201–2238. [3](#), [16](#), [17](#)
- BRUNNERMEIER, M. K., AND Y. SANNIKOV (2014): “A Macroeconomic Model with a Financial Sector,” *The American Economic Review*, 104(2), 379–421. [12](#)
- BRYANT, J. (1980): “A model of reserves, bank runs, and deposit insurance,” *Journal of Banking & Finance*, 4(4), 335–344. [18](#)
- CABALLERO, R., AND A. SIMSEK (2013): “Fire Sales in a Model of Complexity,” *The Journal of Finance*, 68(6), 2549–2587. [18](#)

- CAI, J., A. SAUNDERS, AND S. STEFFEN (2014): “Syndication, interconnectedness and systemic risk,” Working paper. 29, 43
- CALOMIRIS, C. W., AND C. M. KAHN (1991): “The Role of Demandable Debt in Structuring Optimal Banking Arrangements,” *The American Economic Review*, 81(3), 497–513. 3, 18
- CALOMIRIS, C. W., AND J. R. MASON (1997): “Contagion and Bank Failures during the Great Depression: The June 1932 Chicago Banking Panic,” *The American Economic Review*, 87(5), 863–883. 3, 16
- CASTIGLIONESI, F., AND N. NAVARRO (2011): “Fragile Financial Networks,” Working paper. 14
- CERUTTI, E., S. CLAESSENS, AND P. MCGUIRE (2014): “Systemic risks in global banking: what can available data tell us and what more data are needed?,” in *Risk Topography: Systemic Risk and Macro Modeling*, NBER Chapters, pp. 235–260. National Bureau of Economic Research. 44
- CESPA, G., AND T. FOUCAULT (2014): “Illiquidity Contagion and Liquidity Crashes,” *Review of Financial Studies*, 27(6), 1615–1660. 16
- CHAN, N., M. GETMANSKY, S. M. HAAS, AND A. W. LO (2007): “Systemic Risk and Hedge Funds,” in *The Risks of Financial Institutions*, NBER Chapters, pp. 235–338. National Bureau of Economic Research. 11
- CHEN, C., G. IYENGAR, AND C. C. MOALLEMI (2013): “An Axiomatic Approach to Systemic Risk,” *Management Science*, 59(6), 1373–1388. 42
- CHEN, Q., I. GOLDSTEIN, AND W. JIANG (2010): “Payoff complementarities and financial fragility: Evidence from mutual fund outflows,” *Journal of Financial Economics*, 97(2), 239–262. 3, 18
- CHEN, Y. (1999): “Banking Panics: The Role of the First-Come, First-Served Rule and Information Externalities,” *Journal of Political Economy*, 107(5), 946–968. 3, 15
- CIFUENTES, R., H. S. SHIN, AND G. FERRUCCI (2005): “Liquidity Risk and Contagion,” *Journal of the European Economic Association*, 3(2-3), 556–566. 17
- CLAESSENS, S. (2014): “An Overview of Macroprudential Policy Tools,” Working Paper 14/214, International Monetary Fund. 19
- CLERC, L., A. DERVIZ, C. MENDICINO, S. MOYEN, K. NIKOLOV, L. STRACCA, J. SUAREZ, AND A. P. VARDOLAKIS (2015): “Capital Regulation in a Macroeconomic Model with Three Layers of Default,” *International Journal of Central Banking*, 11(3), 9–63. 21
- COVAL, J., AND E. STAFFORD (2007): “Asset fire sales (and purchases) in equity markets,” *Journal of Financial Economics*, 86(2), 479–512. 16
- CROCKETT, A. (2000): “Marrying the micro- and macroprudential dimensions of financial stability,” BIS Speeches. 2
- CROWE, C., G. DELL’ARICCIA, D. IGAN, AND P. RABANAL (2013): “How to deal with real estate booms: Lessons from country experiences,” *Journal of Financial Stability*, 9(3), 300–319. 19

- DANIELSSON, J. (2008): “Blame the models,” *Journal of Financial Stability*, 4(4), 321–328. 21
- DANIELSSON, J., H. S. SHIN, AND J.-P. ZIGRAND (2004): “The impact of risk regulation on price dynamics,” *Journal of Banking & Finance*, 28(5), 1069–1087. 12
- DASGUPTA, A. (2004): “Financial Contagion Through Capital Connections: A Model of the Origins and Spread of Bank Panics,” *Journal of the European Economic Association*, 2(6), 1049–1084. 3, 16
- DE BANDT, O., AND P. HARTMANN (2002): “Systemic Risk: A Survey,” in *Financial Crisis, Contagion and the Lender of Last Resort: A Book of Readings*, ed. by C. Goodhart, and G. Illing, pp. 249–298. Oxford University Press, Oxford. 7
- DE BANDT, O., P. HARTMANN, AND J.-L. PEYDRÓ (2012): “Systemic Risk in Banking: An Update,” in *The Oxford Handbook of Banking*, ed. by A. N. Berger, P. Molyneux, and J. Wilson, pp. 633–672. Oxford University Press. 7
- DE NICOLÓ, G., A. GAMBA, AND M. LUCCHETTA (2014): “Microprudential Regulation in a Dynamic Model of Banking,” *Review of Financial Studies*, 27(7), 2097–2138. 26
- DE NICOLÓ, G., AND M. LUCCHETTA (2011): “Systemic Risks and the Macroeconomy,” in *Quantifying Systemic Risk*, NBER Chapters, pp. 113–148. National Bureau of Economic Research. 3, 30
- DELL’ARICCIA, G., AND R. MARQUEZ (2006): “Competition among regulators and credit market integration,” *Journal of Financial Economics*, 79(2), 401–430. 24
- DIAMOND, D. W., AND P. H. DYBVIK (1983): “Bank Runs, Deposit Insurance, and Liquidity,” *Journal of Political Economy*, 91(3), 401–419. 3, 18
- DIAMOND, D. W., AND R. G. RAJAN (2005): “Liquidity Shortages and Banking Crises,” *The Journal of Finance*, 60(2), 615–647. 17
- DIEBOLD, F. X., AND K. YILMAZ (2014): “On the network topology of variance decompositions: Measuring the connectedness of financial firms,” *Journal of Econometrics*, 182(1), 119–134. 35
- DREHMANN, M., AND N. TARASHEV (2011): “Systemic importance: Some simple indicators,” *BIS Quarterly Review*. 3, 31
- DUARTE, F., AND T. EISENBACH (2015): “Fire-sale spillovers and systemic risk,” Staff Reports 645, Federal Reserve Bank of New York. 3, 32, 43
- DUFFIE, D. (2010): “The Failure Mechanics of Dealer Banks,” *The Journal of Economic Perspectives*, 24(1), 51–72. 18
- (2013): “Replumbing Our Financial System: Uneven Progress,” *International Journal of Central Banking*, 9(S1), 251–279. 22
- (2014): “Financial Market Infrastructure: Too Important to Fail,” in *Across the Great Divide: New Perspectives on the Financial Crisis*, ed. by M. N. Baily, and J. B. Taylor, Book Chapters, chap. 11, pp. 251–257. Hoover Institution, Stanford University. 15

- DUFFIE, D., M. SCHEICHER, AND G. VUILLEMEY (2015): “Central clearing and collateral demand,” *Journal of Financial Economics*, 116(2), 237–256. 3, 22
- DUFFIE, D., AND H. ZHU (2011): “Does a Central Clearing Counterparty Reduce Counterparty Risk?,” *Review of Asset Pricing Studies*, 1(1), 74–95. 3, 15
- EISENBERG, L., AND T. H. NOE (2001): “Systemic Risk in Financial Systems,” *Management Science*, 47(2), 236–249. 14
- ELLAHIE, A. (2013): “Capital Market Consequences of EU Bank Stress Tests,” Working paper. 3, 23
- ELLIOTT, M., B. GOLUB, AND M. O. JACKSON (2014): “Financial Networks and Contagion,” *The American Economic Review*, 104(10), 3115–3153. 14
- ELSINGER, H., A. LEHAR, AND M. SUMMER (2006): “Risk Assessment for Banking Systems,” *Management Science*, 52(9), 1301–1314. 3, 30
- ENGLE, R., E. JONDEAU, AND M. ROCKINGER (2015): “Systemic Risk in Europe,” *Review of Finance*, 19(1), 145–190. 38, 43
- FARBOODI, M. (2015): “Intermediation and Voluntary Exposure to Counterparty Risk,” Working paper. 14
- FARHI, E., AND J. TIROLE (2012): “Collective Moral Hazard, Maturity Mismatch, and Systemic Bailouts,” *The American Economic Review*, 102(1), 60–93. 3, 10
- FINANCIAL STABILITY BOARD (2015): “Principles on Loss-absorbing and Recapitalisation Capacity of G-SIBs in Resolution, Total Loss-absorbing Capacity (TLAC) Term Sheet,” Report. 23
- FLANNERY, M. J. (1996): “Financial Crises, Payment System Problems, and Discount Window Lending,” *Journal of Money, Credit and Banking*, 28(4), 804–824. 3, 17
- FOSTEL, A., AND J. GEANAKOPOLOS (2014): “Endogenous Collateral Constraints and the Leverage Cycle,” *Annual Review of Economics*, 6(1), 771–799. 12
- FREIXAS, X., L. LAEVEN, AND J.-L. PEYDRÓ (2015): *Systemic risk, crises and macroprudential policy*. MIT Press. 7
- FREIXAS, X., AND B. PARIGI (1998): “Contagion and Efficiency in Gross and Net Interbank Payment Systems,” *Journal of Financial Intermediation*, 7(1), 3–31. 3, 15
- FREIXAS, X., B. M. PARIGI, AND J.-C. ROCHET (2000): “Systemic Risk, Interbank Relations, and Liquidity Provision by the Central Bank,” *Journal of Money, Credit and Banking*, 32(3), 611–638. 3, 13
- FREIXAS, X., AND J.-C. ROCHET (2008): *Microeconomics of Banking, 2nd Edition*, vol. 1 of MIT Press Books. The MIT Press. 18
- (2013): “Taming Systemically Important Financial Institutions,” *Journal of Money, Credit and Banking*, 45(s1), 37–58. 3, 12, 23

- GABRIELI, S., AND C.-P. GEORG (2014): “A network view on interbank market freezes,” Discussion Paper 44/2014, Deutsche Bundesbank. [31](#)
- GAI, P., AND S. KAPADIA (2010): “Contagion in financial networks,” *Proceedings of the Royal Society of London A: Mathematical, Physical and Engineering Sciences*, 466(2120), 2401–2423. [14](#)
- GALATI, G., AND R. MOESSNER (2013): “Macroprudential Policy - A literature review,” *Journal of Economic Surveys*, 27(5), 846–878. [19](#)
- GEANAKOPOLOS, J. (1997): “Promises Promises,” in *The Economy as an Evolving Complex System II*, ed. by S. D. W.B. Arthur, and D. Lane, pp. 285–320. Addison-Wesley. [12](#)
- GEANAKOPOLOS, J., AND H. POLEMARCHAKIS (1986): “Existence, Regularity, and Constrained Suboptimality of Competitive Allocations when the Asset Market Is Incomplete,” in *Essays in Honor of Kenneth J. Arrow: Volume 3, Uncertainty, Information, and Communication*, ed. by R. S. W. Heller, and D. Starrett, pp. 65–95. [16](#)
- GENNAIOLI, N., A. SHLEIFER, AND R. W. VISHNY (2013): “A Model of Shadow Banking,” *The Journal of Finance*, 68(4), 1331–1363. [11](#)
- GIESECKE, K., AND B. KIM (2011): “Systemic Risk: What Defaults Are Telling Us,” *Management Science*, 57(8), 1387–1405. [30](#)
- GIGLIO, S. (2014): “Credit default swap spreads and systemic financial risk,” Working paper. [36](#)
- GIGLIO, S., B. T. KELLY, AND S. PRUITT (2015): “Systemic risk and the macroeconomy: an empirical evaluation,” *Journal of Financial Economics*, Forthcoming. [43](#)
- GIRARDI, G., AND A. T. ERGUN (2013): “Systemic risk measurement: Multivariate GARCH estimation of CoVaR,” *Journal of Banking & Finance*, 37(8), 3169–3180. [35](#)
- GLASSERMAN, P., AND H. P. YOUNG (2015): “Contagion in Financial Networks,” Working Paper 15-21, Office of Financial Research. [7](#)
- GOFMAN, M. (2015): “Efficiency and Stability of a Financial Architecture with Too-Interconnected-To-Fail Institutions,” Working paper. [14](#)
- GOLDSTEIN, I., AND Y. LEITNER (2015): “Stress tests and information disclosure,” Working Paper 15-10, Federal Reserve Bank of Philadelphia. [23](#)
- GOLDSTEIN, I., AND A. PAUZNER (2005): “DemandDeposit Contracts and the Probability of Bank Runs,” *The Journal of Finance*, 60(3), 1293–1327. [18](#)
- GOODHART, C. A., A. K. KASHYAP, D. P. TSOMOCOS, AND A. P. VARDOULAKIS (2012): “Financial Regulation in General Equilibrium,” Working Paper 17909, National Bureau of Economic Research. [21](#)
- GORMLEY, T. A., S. JOHNSON, AND C. RHEE (2015): “Ending “Too Big To Fail”: Government Promises Versus Investor Perceptions,” *Review of Finance*, 19(2), 491–518. [22](#)

- GORTON, G., AND A. METRICK (2012): “Securitized banking and the run on repo,” *Journal of Financial Economics*, 104(3), 425–451. [18](#)
- GORTON, G., AND G. ORDONEZ (2014): “Collateral Crises,” *The American Economic Review*, 104(2), 343–378. [17](#)
- GOURIÉROUX, C., J.-C. HÉAM, AND A. MONFORT (2012): “Bilateral exposures and systemic solvency risk,” *Canadian Journal of Economics*, 45(4), 1273–1309. [9](#), [31](#)
- GOURIÉROUX, C., AND A. MONFORT (2013): “Allocating systematic and unsystematic risks in a regulatory perspective,” *International Journal of Theoretical & Applied Finance*, 16(7), 1–20. [42](#)
- GREENWOOD, R., A. LANDIER, AND D. THESMAR (2015): “Vulnerable banks,” *Journal of Financial Economics*, 115(3), 471–485. [3](#), [9](#), [31](#)
- GROMB, D., AND D. VAYANOS (2002): “Equilibrium and welfare in markets with financially constrained arbitrageurs,” *Journal of Financial Economics*, 66(2-3), 361–407. [16](#)
- HAKENES, H., AND I. SCHNABEL (2015): “Regulatory Capture by Sophistication,” Working paper. [27](#)
- HANSEN, L. P. (2013): “Challenges in Identifying and Measuring Systemic Risk,” in *Risk Topography: Systemic Risk and Macro Modeling*, NBER Chapters, pp. 15–30. National Bureau of Economic Research. [42](#)
- HANSON, S. G., A. K. KASHYAP, AND J. C. STEIN (2011): “A Macroprudential Approach to Financial Regulation,” *The Journal of Economic Perspectives*, 25(1), 3–28. [2](#)
- HARTMANN, P., S. STRAETMANS, AND C. DE VRIES (2007): “Banking System Stability. A Cross-Atlantic Perspective,” in *The Risks of Financial Institutions*, NBER Chapters, pp. 133–192. National Bureau of Economic Research. [35](#)
- HAUTSCH, N., J. SCHAUMBURG, AND M. SCHIENLE (2015): “Financial Network Systemic Risk Contributions,” *Review of Finance*, 19(2), 685–738. [36](#)
- HE, Z., AND A. KRISHNAMURTHY (2014): “A Macroeconomic Framework for Quantifying Systemic Risk,” Working Paper 19885, National Bureau of Economic Research. [3](#), [30](#)
- HE, Z., AND W. XIONG (2012): “Dynamic Debt Runs,” *Review of Financial Studies*, 25(6), 1799–1843. [18](#)
- HEIDER, F., M. HOEROVA, AND C. HOLTHAUSEN (2015): “Liquidity hoarding and interbank market spreads: the role of counterparty risk,” *Journal of Financial Economics*, Forthcoming. [3](#), [17](#)
- HIRTLE, B., AND A. LEHNERT (2014): “Supervisory stress tests,” Staff Reports 696, Federal Reserve Bank of New York. [23](#)
- HOLMSTROM, B., AND J. TIROLE (1997): “Financial Intermediation, Loanable Funds, and the Real Sector,” *The Quarterly Journal of Economics*, 112(3), 663–691. [12](#)

- HOLTHAUSEN, C., AND T. RØNDE (2002): “Regulating Access to International Large-Value Payment Systems,” *Review of Financial Studies*, 15(5), 1561–1586. 15
- HUANG, X., H. ZHOU, AND H. ZHU (2009): “A framework for assessing the systemic risk of major financial institutions,” *Journal of Banking & Finance*, 33(11), 2036–2049. 36
- IDIER, J., G. LAMÉ, AND J.-S. MÉSONNIER (2014): “How useful is the Marginal Expected Shortfall for the measurement of systemic exposure? A practical assessment,” *Journal of Banking & Finance*, 47, 134–146. 43
- IYER, R., AND J.-L. PEYDRÓ (2011): “Interbank Contagion at Work: Evidence from a Natural Experiment,” *Review of Financial Studies*, 24(4), 1337–1377. 3, 31
- IYER, R., AND M. PURI (2012): “Understanding Bank Runs: The Importance of Depositor-Bank Relationships and Networks,” *The American Economic Review*, 102(4), 1414–45. 3
- JEANNE, O., AND A. KORINEK (2013): “Macroprudential Regulation Versus Mopping Up After the Crash,” Working Paper 18675, National Bureau of Economic Research. 27
- JIMÉNEZ, G., S. ONGENA, J.-L. PEYDRÓ, AND J. SAURINA (2015): “Macroprudential Policy, Countercyclical Bank Capital Buffers and Credit Supply: Evidence from the Spanish Dynamic Provisioning Experiments,” Working paper. 3, 20
- JOBST, A. A. (2014): “Measuring systemic risk-adjusted liquidity (SRL) - A model approach,” *Journal of Banking & Finance*, 45, 270–287. 3, 20, 32
- KELLY, B., H. LUSTIG, AND S. VAN NIEUWERBURGH (2012): “Too-Systemic-To-Fail: What Option Markets Imply About Sector-wide Government Guarantees,” Working paper. 36
- KIYOTAKI, N., AND J. MOORE (1997): “Credit Cycles,” *Journal of Political Economy*, 105(2), 211–248. 3, 12
- KODRES, L. E., AND M. PRITSKER (2002): “A Rational Expectations Model of Financial Contagion,” *The Journal of Finance*, 57(2), 769–799. 17
- KOEPPL, T., C. MONNET, AND T. TEMZELIDES (2012): “Optimal clearing arrangements for financial trades,” *Journal of Financial Economics*, 103(1), 189–203. 15
- KOMAI, A., AND G. RICHARDSON (2011): “A Brief History of Regulations Regarding Financial Markets in the United States: 1789 to 2009,” Working Paper 17443, National Bureau of Economic Research. 24
- KORINEK, A. (2012): “Systemic risk-taking: amplification effects, externalities, and regulatory responses,” Working paper. 27
- KRITZMAN, M., Y. LI, S. PAGE, AND R. RIGOBON (2011): “Principal component as a measure of systemic risk,” *Journal of Portfolio Management*, 37(4), 112–126. 35
- LAGUNOFF, R., AND S. L. SCHREFT (2001): “A Model of Financial Fragility,” *Journal of Economic Theory*, 99(1-2), 220–264. 18

- LANDIER, A., AND D. THESMAR (2014): “Regulating Systemic Risk through Transparency: Trade-Offs in Making Data Public,” in *Risk Topography: Systemic Risk and Macro Modeling*, NBER Chapters, pp. 31–44. National Bureau of Economic Research. 23
- LEHAR, A. (2005): “Measuring systemic risk: A risk management approach,” *Journal of Banking & Finance*, 29(10), 2577–2603. 3, 29
- LEITNER, Y. (2005): “Financial Networks: Contagion, Commitment, and Private Sector Bailouts,” *The Journal of Finance*, 60(6), 2925–2953. 14
- MARKOSE, S. M. (2012): “Systemic Risk from Global Financial Derivatives: A Network Analysis of Contagion and Its Mitigation with Super-Spreader Tax,” Working Paper 12/282, International Monetary Fund. 30
- MARKOSE, S. M., S. GIANANTE, AND A. R. SHAGHAGHI (2012): “Too interconnected to fail financial network of US CDS market: Topological fragility and systemic risk,” *Journal of Economic Behavior & Organization*, 83(3), 627–646. 38
- MARTIN, A., D. SKEIE, AND E.-L. VON THADDEN (2014): “Repo Runs,” *Review of Financial Studies*, 27(4), 957–989. 3, 18
- MCANDREWS, J. J., AND S. M. POTTER (2002): “Liquidity effects of the events of September 11, 2001,” *Economic Policy Review*, 8(2), 59–79. 3, 15
- MINSKY, H. P. (1992): “The Financial Instability Hypothesis,” Working paper. 12
- MOENNINGHOFF, S. C., S. ONGENA, AND A. WIEANDT (2015): “The perennial challenge to counter Too-Big-to-Fail in banking: Empirical evidence from the new international regulation dealing with Global Systemically Important Banks,” *Journal of Banking & Finance*, 61, 221–236. 3, 24
- MOESSNER, R., AND W. A. ALLEN (2013): “Central bank swap line effectiveness during the euro area sovereign debt crisis,” *Journal of International Money and Finance*, 35, 167–178. 11
- MORGAN, D. P., S. PERISTIANI, AND V. SAVINO (2014): “The Information Value of the Stress Test.,” *Journal of Money, Credit & Banking*, 46(7), 1479–1500. 23
- MORRIS, S., AND H. S. SHIN (2008): “Financial Regulation in a System Context,” *Brookings Papers on Economic Activity*, 39(2), 229–274. 21
- (2012): “Contagious Adverse Selection,” *American Economic Journal: Macroeconomics*, 4(1), 1–21. 18
- NIER, E., J. YANG, T. YORULMAZER, AND A. ALENTORN (2007): “Network models and financial stability,” *Journal of Economic Dynamics and Control*, 31(6), 2033–2060. 14
- OH, D. H., AND A. PATTON (2015): “Time-varying systemic risk: evidence from a dynamic copula model of CDS spreads,” Working paper. 36
- O’HARA, M., AND W. SHAW (1990): “Deposit Insurance and Wealth Effects: The Value of Being Too Big to Fail,” *The Journal of Finance*, 45(5), 1587–1600. 22

- OLIVEIRA, R. D. F., R. F. SCHIOZER, AND L. A. B. D. C. BARROS (2015): “Depositors Perception of Too-Big-to-Fail,” *Review of Finance*, 19(1), 191–227. 22
- ONO, A., H. UCHIDA, G. UDELL, AND I. UESUGI (2013): “A Close Look at Loan-To-Value Ratios: Evidence from the Japanese Real Estate Market,” Working Paper Series 19, Center for Interfirm Network, Institute of Economic Research, Hitotsubashi University. 3, 19
- PEROTTI, E. C., L. RATNOVSKI, AND R. VLAHU (2011): “Capital Regulation and Tail Risk,” *International Journal of Central Banking*, 7(4), 123–163. 3, 11
- PEROTTI, E. C., AND J. SUAREZ (2002): “Last bank standing: What do I gain if you fail?,” *European Economic Review*, 46(9), 1599–1622. 10
- (2011): “A Pigovian Approach to Liquidity Regulation,” *International Journal of Central Banking*, 7(4), 3–41. 20
- PETRELLA, G., AND A. RESTI (2013): “Supervisors as information producers: Do stress tests reduce bank opaqueness?,” *Journal of Banking & Finance*, 37(12), 5406–5420. 3, 23
- PHILIPPON, T., AND V. SKRETA (2012): “Optimal Interventions in Markets with Adverse Selection,” *The American Economic Review*, 102(1), 1–28. 22
- PLANTIN, G., H. SAPRA, AND H. S. SHIN (2008): “Marking-to-Market: Panacea or Pandora’s Box?,” *Journal of Accounting Research*, 46(2), 435–460. 16
- ROCHET, J.-C. (2010): “The Future of Banking Regulation,” in *Balancing the Banks*, ed. by M. Dewatripont, J.-C. Rochet, and J. Tirole, pp. 78–106. Princeton University Press, Princeton. 22
- ROCHET, J.-C., AND J. TIROLE (1996a): “Controlling Risk in Payment Systems,” *Journal of Money, Credit and Banking*, 28(4), 832–862. 2, 3, 15
- (1996b): “Interbank Lending and Systemic Risk,” *Journal of Money, Credit and Banking*, 28(4), 733–762. 22
- RODRÍGUEZ-MORENO, M., AND J. I. PEÑA (2013): “Systemic risk measures: The simpler the better?,” *Journal of Banking & Finance*, 37(6), 1817–1831. 43
- SCAILLET, O. (2004): “Nonparametric estimation and sensitivity analysis of expected shortfall,” *Mathematical Finance*, 14(1), 115–129. 33
- SEGOVIANO, M., AND C. GOODHART (2009): “Banking stability measures,” Working Paper 09/4, International Monetary Fund. 36
- SHLEIFER, A., AND R. W. VISHNY (1992): “Liquidation Values and Debt Capacity: A Market Equilibrium Approach,” *The Journal of Finance*, 47(4), 1343–1366. 3, 16
- (1997): “The Limits of Arbitrage,” *The Journal of Finance*, 52(1), 35–55. 16
- STEIN, J. C. (2012): “Monetary Policy as Financial Stability Regulation,” *The Quarterly Journal of Economics*, 127(1), 57–95. 20

- STIGLITZ, J. E. (1982): “The Inefficiency of the Stock Market Equilibrium,” *Review of Economic Studies*, 49(2), 241–261. 16
- SUNDARESAN, S., AND Z. WANG (2015): “On the Design of Contingent Capital with a Market Trigger,” *The Journal of Finance*, 70(2), 881–920. 23
- TIROLE, J. (2011): “Illiquidity and all its friends,” *Journal of Economic Literature*, 49(2), 287–325. 20
- (2012): “Overcoming Adverse Selection: How Public Intervention Can Restore Market Functioning,” *The American Economic Review*, 102(1), 29–59. 22
- UPPER, C. (2011): “Simulation methods to assess the danger of contagion in interbank markets,” *Journal of Financial Stability*, 7(3), 111–125. 30
- UPPER, C., AND A. WORMS (2004): “Estimating bilateral exposures in the German interbank market: Is there a danger of contagion?,” *European Economic Review*, 48(4), 827–849. 30
- WAGNER, W. (2010): “Diversification at financial institutions and systemic crises,” *Journal of Financial Intermediation*, 19(3), 373–386. 21
- WU, D., AND X. S. ZHAO (2014): “Systemic risk and bank failure,” Working paper. 43
- ZAWADOWSKI, A. (2013): “Entangled Financial Systems,” *Review of Financial Studies*, 26(5), 1291–1323. 15