



HAL
open science

The Arles-Rhône 3 project : From the excavation and raising of a Gallo-Roman barge, in the southern coastal French city of Arles, to its documentation and modelling in 3D (2011-2012)

Sabrina Marlier, Pierre Poveda, Nicolas Ranchin

► To cite this version:

Sabrina Marlier, Pierre Poveda, Nicolas Ranchin. The Arles-Rhône 3 project : From the excavation and raising of a Gallo-Roman barge, in the southern coastal French city of Arles, to its documentation and modelling in 3D (2011-2012). 13th International Symposium on Boat and Ship Archaeology, Jerzy Gawronski; André van Holk; Beno van Tillburg, Oct 2012, Amsterdam, Netherlands. pp.383-389. halshs-01807685

HAL Id: halshs-01807685

<https://shs.hal.science/halshs-01807685v1>

Submitted on 15 Jan 2019

HAL is a multi-disciplinary open access archive for the deposit and dissemination of scientific research documents, whether they are published or not. The documents may come from teaching and research institutions in France or abroad, or from public or private research centers.

L'archive ouverte pluridisciplinaire **HAL**, est destinée au dépôt et à la diffusion de documents scientifiques de niveau recherche, publiés ou non, émanant des établissements d'enseignement et de recherche français ou étrangers, des laboratoires publics ou privés.

60. The Arles-Rhône 3 project (Arles, France). From the excavation and raising of a Gallo-Roman barge to its documentation and 3D-modelling (2011-2012)

Sabrina Marlier, Pierre Poveda & Nicolas Ranchin

Introduction

The Arles-Rhône 3 (AR3) shipwreck was discovered in 2004 on the right bank of the Rhône river, in Arles, during the creation of an archaeological coast survey map of the area, directed by Luc Long, of the French Department of Underwater Archaeological Research (Drassm) (Long in Long & Picard, 2009: 233-234). Situated between 4 and 9 m of depth and on a 35° sloping bank, the wreck was embedded in harbour garbage dump of the city of Arles from the Roman period, which represented a stratigraphical context of extremely important archaeological material (Djaoui *et al.*, 2011). Between 2005 and 2010, a number of assessments, a survey and finally an excavation of the shipwreck were carried out. These operations were conducted by the Arkaeos Association, with the collaboration of the Arles Museum of Antiquity, the Centre Camille Jullian/CNRS and the Drassm. The results showed the importance and value of this shipwreck, which was identified as a Gallo-Roman barge dated from the middle of the 1st century BC (Long *et al.*, 2009; Marlier, 2011; Marlier *et al.*, 2012).

Characteristics and state of conservation of the AR3 shipwreck

- 1 The shipwreck corresponds to a barge that sank when it was still in use: this is not an abandoned boat. Thus, the wreck has conserved its galley gear with the glazed ceramic, and one *dolium*, reused as a *brasero* for cooking as well as other tools. Also the barge's cargo was preserved in place, consisting of 21 to 31 tonnes of limestone blocks from neighbouring quarries located 15 km north of Arles (*Ernaginum*/Tarascon), thus indicating the direction of the boat during its last trip.
- 2 Concerning its state of conservation, except for one part of the aft port side that is missing, the wood is very well preserved and the barge is complete from

one end to the other - even in its upper part, up to the gunwale. Moreover, all the internal wooden elements related to the galley gear and tools, and to the cargo have been preserved.

- 3 One steering oar, associated with the barge because of its appropriate ratio and its similar dating, was also discovered close to the shipwreck in 2004 (Long in Long & Picard, 2009: 240 and 242).
- 4 Finally, the boat presented one inscription (C.L.POSTV) stamped in the wood of the starboard side, in the aft section (Djaoui *et al.*, 2011: 156).

Excavation and raising of the AR3 shipwreck

Because of the special characteristics of the AR3 shipwreck, at the end of 2010 the General Council of the Bouches-du-Rhône, to which the Arles Museum of Antiquity belongs, decided with the Drassm to complete the excavation and to raise this Gallo-Roman barge in order to restore it and to present it within the Arles Museum. In order to accommodate the reconstructed shipwreck, the museum was expanded in 2012. The 800-m² extension, which was inaugurated in October 2013, hosts more than 400 objects in connection with the commercial activities, shipping and port activities of the city of Arles in Roman times. Furthermore, the French Ministry of Culture has classified this boat as a *Trésor National* ('National Treasure'). The entire operation was linked to the cultural manifestations of Marseille-Provence in 2013, the year where the city and its region were named European capital of Culture. Due to this event, the deadlines for the end of the excavation and the raising of the barge, as well as the restoration and reassembly, have been very short.

The concluding excavation and raising of the barge took place in 2011 over a period of seven months (fig. 1). This operation mobilized important means (€ 1.9M)¹ and was created within the framework of a government contract; a tender won by the French operators Ipso Facto,



Fig.1. Raising of one of the ten sections of the Arles-Rhône 3 barge with, in the background, on the left bank of the Rhone, the blue archaeological museum (Photo: © Teddy Seguin, O'Can-Ipso Facto, Mdaa/CG13).



Fig. 2. 3D recording using a C-Track (Photo: © Teddy Seguin, O'Can-Ipso Facto, Mdaa/CG13).

specialized in underwater archaeology, and O'Can, specialized in underwater public works.³ The operation was directed by Sabrina Marlier (Mdaa), David Djaoui (Mdaa), Mourad El Amouri (Ipsos Facto), Sandra Greck (Ipsos Facto) and Benoît Poinard (O'Can) and executed by a mixed team, composed of archaeologists and underwater archaeologists (Arles Museum of Antiquity, DRASSM and Ipsos Facto), commercial divers (O'Can) and conservator-restorers (Ipsos Facto, Arles Museum of Antiquity, Arc-Nucléart and A-Corros). This undertaking has allowed to finally complete this exhaustive excavation, which began in 2008, and led to the raising of the barge in 2011, measuring 31 m in length, in 10 sections according to a method specially designed for the occasion by the foreman, Benoît Poinard, in partnership with the engineering office of Ipsos Facto. First documented underwater during the excavation, the raised sections of the boat were then meticulously and exhaustively documented on the ground before their transport to the city of Grenoble, where the conservation laboratory Arc-Nucléart is located. This documentation included:

- Precise observations;
- Sampling fabrics and pitch for further analysis;
- Identification of the wood species used for the construction of the boat;
- Extensive photographic recording to support the study of the architectural characteristics, as well as the dendrochronological analyses;
- 3D drawing of all the sections and other wooden elements of the boat was added to these classical ways of documentation.

Documentation and modelling in 3D of the AR3 shipwreck

The device chosen for this project, from the Canadian company Créaform 3D, had never been used for archaeological purposes before. It consisted of a 3-dimensional recording instrument compatible with the Rhinoceros 3D software, like the now standard FaroArm, with the particularity of being wireless (fig. 2). It is composed of three complimentary elements:

- 1 HandyPROBE: a wireless probe with nine reflective targets on it used in the recording phase. The tip of the probe is positioned on the point to be recorded, and the digital data recorded are instantly transferred to the software and computer once the trigger on the probe is activated.
- 2 C-Track: two infrared cameras set in a case mounted on a photography ball-head and tripod. Their function is to track 'live' the movement of the probe and to record the digital data captured with the probe. The moment the trigger is activated, an instant triangulation is made between the two cameras and each of the nine targets on the probe.

- 3 The reflective targets: placed all around the subject to be recorded to create a reference system within a digital space. It allows the C-Track to follow the HandyPROBE within the reference system, and insures precise measurements. Once the reference system in place, both the probe and the C-Track may move freely within the digital space without the C-Track ever losing its orientation.

The digital recording methodology was broken down into two separate phases: one 'macro' and one 'micro'. The 'macro' phase consisted of recording whole segments, with all the architectural elements composing them still assembled to one another. This unique opportunity allowed to produce accurate and precise documentation. This type of recording was nevertheless difficult to accomplish due to the chain of operational processes set in place. Between the moment a segment was raised from the Rhone river and the moment it was conditioned and packed by the conservation team to be shipped to the restoration laboratory at Arc-Nucléart, archaeologists had only one week to accomplish every single documentation task. With the digital recording representing just one aspect of documentation, the 'macro' recording phase could not exceed 48 hours in order not to block the other documentation tasks.

The second recording phase was the 'micro' documentation. This consisted of recording mobile elements in detail, such as the planking at the bottom of the bulkhead, or elements removed after the 'macro' phase, such as the side planks. It is important to note that the contour of the elements that were to be documented in the 'micro' phase were quickly drawn in the 'macro' phase to facilitate their placement in 2D and 3D plans during post-treatment.

The documentation procedure itself consisted of recording the visible facets of each architectural element by connecting points captured in 3D to form polyline assemblages. The next step was to export the unedited files with high-precision raw results to Adobe Illustrator to generate technical plans that others on the project could immediately use for their own documentation tasks. Each plan depicted either a whole segment or independent architectural elements seen from different perspectives onto which individuals could add their own notes and observations (for example, the location of iron nails taken out of the half trunk flanks during disassembly). These sheets allowed us to create a certain homogeneity and consistency in the sharing of information between the various teams in the field.

Following a four months period of intensive use, a primary report on the utilization of the C-Track for nautical archaeology purposes could be drafted. The major advantage of this instrument is that it is wireless. This granted a great freedom of movement, without ever having to disassemble each architectural element. This also helped to drastically shorten the recording time without ever neglecting data quality. That being the

case, the C-Track does also present noticeable disadvantages. To mention one; it is extremely sensitive to the work environment. Originally designed to be used in a controlled environment protected from the elements, it was instead used in extreme conditions throughout the project that caused the instrument to malfunction, slow-down, and in some instances to shut-down altogether. Furthermore, the C-Track is a contact-based recording tool, which is not preferable when wanting to preserve the physical integrity of a subject.

Post-processing phase

The first step consisted of assembling under one master file every single separate segment, as well as all the loose elements, such as the bulkhead, that had been recorded at various times throughout the project. This task, accomplished by using the Rhinoceros 3D software, utilized both fixed reference points recorded on each segment during its respective 'macro' documentation, and the description of certain architectural characteristics. Thus, in order to reconnect two adjacent segments, we based ourselves on the outward faces of the various architectural components created along the cutting line. Their perfect realignment allowed to capture the original position of each segment in relation to the adjacent segment. In terms of integrating micro records into larger macro files, such as with the detailed recording of a side plank which needed to be reintegrated back into its corresponding segment, we based ourselves on the repositioning of noticeable topographical points set up beforehand on both the individual elements and on the larger segments to which they belonged. Upon completing this task, we had a primary archive of the digitally recorded barge in which each architectural element could be isolated and highlighted. This nevertheless

represented a basic archive that required a large amount of cleaning up and reworking of the recordings in order to get the documentation needed for the study and publication.

Restoration of shapes and missing parts

Next, considering the very good preservation state of the barge, it seemed necessary to attempt to restore the few missing parts, as well as to try to straighten out the various deformations of the wreck. The purpose of this task was to establish as precisely as we could the weight and tonnage of the barge, as well as its draught and stability.

Two more problematic issues particularly caught our attention during this restoration task: on the one hand we needed to recover the aperture angle at which the side planks opened up after being seriously deformed over time in the water³, and on the other hand we wanted to figure out how to fill in the missing elements from the barge's stern. Relating to the side planks' aperture angle, the only unquestionable point of reference was located at the mast-thwart, the length of which allowed us to define the aperture angle at which the side planks opened up at that exact point. From there, and based on a symmetrical opening on both sides, it appeared that the initial opening angle of the flanks was 92°. Regarding the restoration of missing parts at the stern, the first step consisted of symmetrically restoring the port side assemblage based on the preserved starboard side. At the stern, considering the replacement of the steering oar and the positioning of the helmsman that we could deduce, we favoured the hypothesis of a one-piece rear transom onto which the steering oar would rest, similar to that which has been done on



Fig. 3. The 3D restoration (Model: © Pierre Poveda, Ipso Facto).

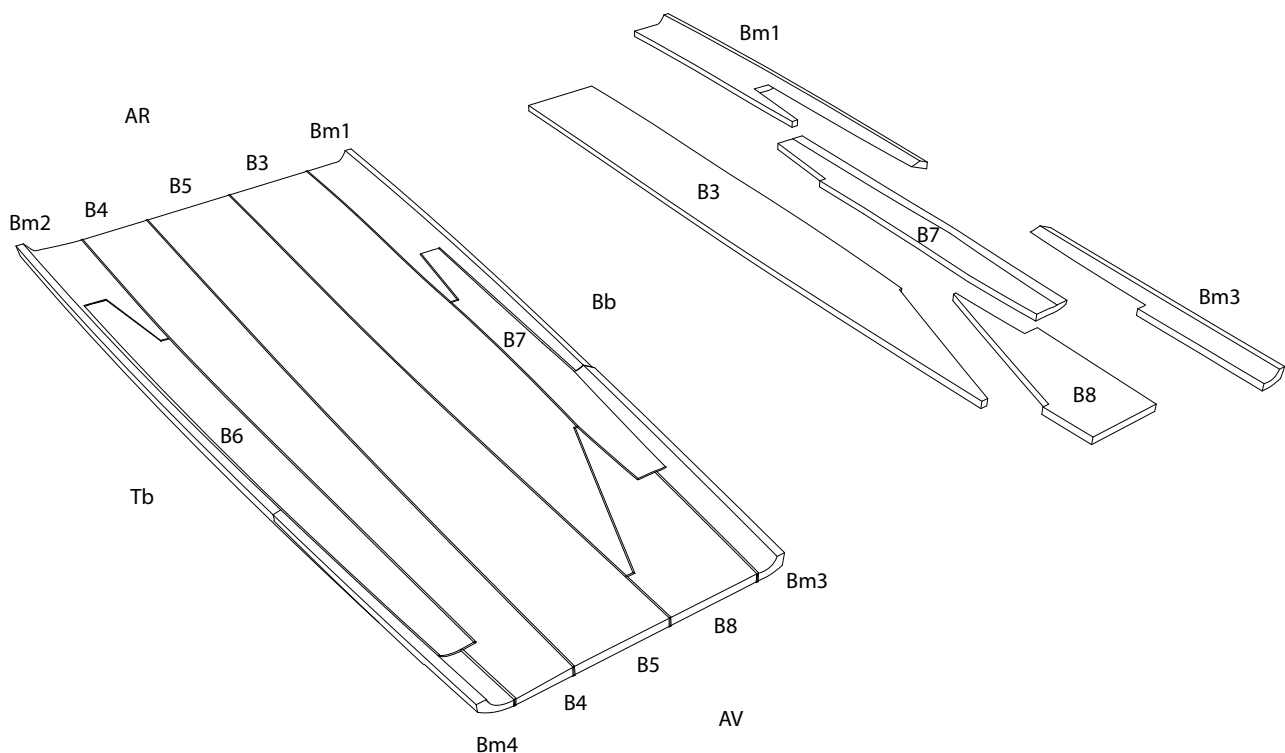

Fig. 4. Perspective view of the assemblies of the monoxylous hard-chine bilges (BM1-BM3 and BM2-BM4) with the secondary planks (B7 and B6) located at the bow, near the mast-step frame (Drawing: © Pierre Poveda, Ipso Facto).

the Altaripa Gallo-Roman barge replica discovered in Bevaix, Switzerland (Arnold, 1999: 151).

Overall weight and tonnage analysis

The overall restoration, resulting in a complete 3D model achieved with Rhinoceros, has enabled us to draft the barge's restored line plan from which we can run a certain number of tests that will enable us to refine our perception of the ship's utilization. First, it is by identifying the type of wood used in the barge's construction, as well as the volume of its individual elements, that we were able to determine precisely the overall weight of the empty barge, which we estimate at 8.13 t. Similarly, based on the bulkhead's restoration, we were able to determine the exact volume available for cargo. Knowing the density of the rocks as well as their average stowage factor, we estimate the cargo weight at 21,48 t, which would represent a significant, yet possible, draught for the barge. This first analysis phase should continue in order to refine our understanding of the barge and its usage by determining, for example, the hull resistance and the barge's manoeuvrability.

The main features of the ship structure

In relation with the modelling and restitution works done on the Arles-Rhône 3 barge, the architectural study reveal a 'bottom-based' construction for which the main features of the structure are the following.

The bottom

The bottom of the Arles-Rhône 3 barge is composed of three main strakes and two secondary planks located at the bow, near the mast-step frame. All the planks are made of oak⁴ and are placed edge to edge, without any form of assembly between them, except at the extremities of the plank joints where transversal nails were used for their connection to the adjacent planks.

The monoxylous hard-chine bilges and the composite bilge strakes

To ensure the transition between the bottom and the sides of the boat, the design of the bilges is very complex. A combination has been applied of two principal monoxylous hard-chine bilges, in the central part of the boat and in the fore part, and of composite bilge strakes in the aft and also near the mast-step frame and at the end

of the bow. The monoxyulous hard-chine bilge strakes are made of oak and form an 'L' shape, slightly rounded and in an almost right angle with the bottom. In addition to ensuring the transition between bottom and sides, these pieces give a structural longitudinal rigidity to the boat. The composite bilge strakes are made of a vertical plank assembled to the adjacent plank on the bottom by means of a transversal nail inserted from the outside.

The frames

The framing-system consists of 47 flat floor-timbers and some occasional knees (20), all also made of oak. On the fore and on the aft parts of the boat, the spacing between the frames is very wide (40.27 to 48.70 cm). By contrast, in the central part of the boat, due to the heavy cargo, the space between the frames is much tighter (31.96 cm on av.). For the same reason, the dimensions of the flat floor timbers are in the central part of the boat (L.: 22-27 to 28-34 cm; H.: 8.2 cm on av.) than in the fore and the aft parts (L.: 14.5 to 31 cm; H.: 6.6 cm on av.). The mast-step is a great flat floor-timber of 42 cm in width for a thickness of 8.5 to 12.5 cm. Concerning the lengths of the frames as they correspond to the internal width of the boat, there is no real main frame that can be defined but rather a wider zone of the boat: this beam, situated in the central part, measures about 2.30 m. The floor-timbers are flat with rounded inner edges, never exceeding the top edge of the chine-strake.

The monoxyulous side planks

Over the total length of the boat, the sides are composed of monoxyulous side planks made of a half-trunk of fir. Arranged perfectly symmetrically on each side of the boat, the principal monoxyulous side planks measure more than 26 m in length. With a maximal height of 90 cm and a maximal thickness of 21 cm, they also provide longitudinal rigidity to the barge. They are fitted to the bilge strakes by means of iron nails inserted obliquely from the lower external face of the monoxyulous pieces through the bilge strakes where the tips are driven back at a right angle. The upper parts of the monoxyulous side planks are also fitted to the knees by iron nails. On the fore and on the aft of the boat, some gunwales, made out of oak, are nailed to the upper part of the monoxyulous side planks.

The mast thwart

Located above the mast-step frame, the mast thwart lies on longitudinal fittings upon which knees are mounted and fastened. The mast thwart has rather large dimensions, similar to the mast-step frame. In the centre of the piece, a circular opening of 16 cm in diameter is pierced for the passage of the mast. This mast was discovered under the stone cargo. It corresponds to the towing mast and measures 3.70 m in length. It is made of ash.

Nail fastenings

All the frames, flat floor timbers and knees are fitted with iron nails to the bottom, to the bilge strakes and to the sides. For the assembly to the planks on the bottom, the nails are inserted from the back of the frames and from the outside of the bottom in order to form a strong cross assembly. All nails have a folded tip, while the tip of the nails inserted from the back of the frames is double folded on the outside of the bottom, creating a hook. The nails ensure not only the assembly of the frames but also the cohesion of the complete structure of the boat as the planks are not connected. There are nearly 1,700 nails used for the assembly of all the structures of the barge with two different sizes of nails.⁵ Moreover, a great number of metallic elements were used to lock some scarfs between two planks or to strengthen the bow, which is filiform.

The watertightness

The boat is made watertight by means of wool fabrics with pitch placed between the planks according to the luting technique. The pollen analyses of the pitch revealed the presence of some olive tree taxa, which points towards a local construction of the boat. Numerous traces of pitch, found both inside and outside the hull, also contribute to the watertightness of the boat.

The internal wooden structures

Linked to the galley gear and tools, and to the cargo, two types of internal wooden structures were placed in the boat: on the aft part, in relation with the cooking and the working activities of the boatmen, a series of planks, of resinous species, were glued with pitch directly against the bottom or on the frame. In the central part, an open hold constituted of about 140 longitudinal and transversal-stacked movable timbers, and also made of resinous species, allowed to protect the structure of the hull and to contain the heavy cargo.

Shape and dimensions

The complete barge measures 31 m in length, with a width of 2.90 m, and a height of about 1 m. It is a long and narrow barge, with a very tapered bow until today never observed on other Gallo-Roman barges discovered in Europe. This boat is very well built, in a very complex fashion, with particular attention paid to the perfect symmetry of the numerous arrangements of various elements and structures.

Conclusion

After four years of excavations and one year (2011) for the remaining fieldwork and the raising and documentation of the shipwreck, the Arles-Rhône 3 project has

now been completed and the scientific publication is finished (Marlier, 2014). Parallel with the research, the barge was restored and reassembled and can be seen on display in the Arles Museum of Antiquity. The successful completion of this undertaking within a very short time is firstly due to the high degree of competence of all of the excellent professionals who intervened at all levels for this exceptional project, secondly to the important means provided by the politicians and one great patron, and finally to the generosity of the Rhône river that allowed us to dive every scheduled day (except for one week) in 2011, from May to November, in order to achieve our goal.

Notes

- 1 The whole operation Arles-Rhône 3 (excavation, raising, restoration, extension of the Museum and exhibit design) costed € 10M: € 7M were funded by the Collectivity (Conseil Général des Bouches-du-Rhône), € 2.5M by a patron (the Compagnie Nationale du Rhône), € 400.000 by the French Ministry of Culture and € 80.000 by the Collectivity Provence Alpes Côte d'Azur Region.
- 2 <http://www.ips-o.fr/>; <http://www.ocan.fr/>.
- 3 The disparities observed around the preserved angles on the transversal knees has quickly led us to decide not to include them in the restitution due to important deformations.
- 4 All wood determinations were done by Sandra Greck (Ipsos Facto).
- 5 The smaller size is of 16 cm on av. (L) with a diameter of the head of 23-26 mm and a section of the stem of 8-9 mm; the largest size is of 20 cm on av. (L) with a diameter of the head of 27-29 mm and a section of the stem of 8-9 mm.

References

- Arnold, B., 1999. *Altariipa. Archéologie expérimentale et architecture navale gallo-romaine*. Archéologie Neuchâteloise 25.
- Djaoui, D., Greck, S. & Marlier, S. (eds), 2011. *Arles-Rhône 3. Le naufrage d'un chaland antique dans le Rhône, enquête pluridisciplinaire*. Actes Sud, Arles.
- Greck, S. & Guibal, F., 2011. Étude dendrologique de l'épave Arles-Rhône 3. In: G. Boetto, P. Pomey & A. Tchernia (eds), *Batellerie gallo-romaine: pratiques régionales et influences maritimes méditerranéennes, Actes de la table-ronde internationale, 27-28 oct. 2008 (Aix-en-Provence, MMSH)*. Bibliothèque d'Archéologie Méditerranéenne et Africaine 9. Centre Camille Jullian, Editions Errance: 153-164.
- Long, L. & Picard, P. (eds), 2009. *César. Le Rhône pour mémoire. Vingt de fouilles dans le fleuve à Arles*. Catalogue d'exposition, Musée départemental Arles antique, Arles. Actes Sud, Arles.
- Long, L., Rival, M. & Marlier, S., 2009. The Gallo-Roman Wreck Arles-Rhône 3. In: R. Bockius (ed.), *Between the Seas. Transfer and Exchange in Nautical Technology. Proceedings of the Eleventh International Symposium on Boat and Ship Archaeology, Mainz 2006*. Römisch-Germanisches Zentralmuseum Tagungen 3, Mainz: 303-311.
- Marlier, S., 2009. Le Rhône, autoroute fluviale. In: Long & Picard, 2009: 28-35.
- Marlier, S., 2011. L'épave Arles-Rhône 3: étude préliminaire d'un chaland gallo-romain. In: G. Boetto, P. Pomey & A. Tchernia (eds), *Batellerie gallo-romaine: pratiques régionales et influences maritimes méditerranéennes, Actes de la table-ronde internationale, 27-28 oct. 2008 (Aix-en-Provence, MMSH)*. Bibliothèque d'Archéologie Méditerranéenne et Africaine 9. Centre Camille Jullian, Éditions Errance, Paris: 131-151.
- Marlier, S. (ed.), 2014. *Arles-Rhône 3. Un chaland gallo-romain du I^{er} siècle après Jésus-Christ*. Archaeonautica 18. Éditions du CNRS, Paris, en co-édition avec le Musée départemental Arles antique, Arles.
- Marlier, S., Greck, S., Guibal, F. & Andrieu-Ponel, V., 2012. Arles-Rhône 3: Architectural and Paleobotanical Study of a Gallo-Roman Barge from the 1st Century in the Rhône river. In: N. Günsenin (ed.), *Between Continents. Proceedings of the Twelfth Symposium on Boat and Ship Archaeology, Istanbul 2009*. Ege Yayinlari, Istanbul: 203-210.
- Marlier, S., Djaoui, D., El Amouri, M., Greck, S. & Poinard, B., 2013. Arles-Rhône 3 - Ausgrabung und Bergung eines Römischen Lastkahns (Arles, Frankreich). In: M. Reinfeld (ed.), *Archäologie im Mittelmeer*. Verlag Philipp von Zabern, Darmstadt/Mainz: 177-184.
- Marlier, S. & Rieth, E., (in press). Le chaland Arles-Rhône 3: présentation architecturale et particularités au sein de la construction navale gallo-romaine, actes du colloque. *La construction navale et ses objets: nouvelles approches, nouveaux outils* (Nantes, 20-21 septembre 2012).