



HAL
open science

Empty Mind: An exploration towards an autonomous digital experience and aesthetics within a virtual live performance End report for DARIAH-EU THEME 2020: Arts Exchanges

Ine Vanoeveren, Kristof Timmerman

► **To cite this version:**

Ine Vanoeveren, Kristof Timmerman. Empty Mind: An exploration towards an autonomous digital experience and aesthetics within a virtual live performance End report for DARIAH-EU THEME 2020: Arts Exchanges. [Research Report] Royal Academy of Fine Arts Antwerp; AP Hogeschool. 2022. halshs-03791432

HAL Id: halshs-03791432

<https://shs.hal.science/halshs-03791432>

Submitted on 29 Sep 2022

HAL is a multi-disciplinary open access archive for the deposit and dissemination of scientific research documents, whether they are published or not. The documents may come from teaching and research institutions in France or abroad, or from public or private research centers.

L'archive ouverte pluridisciplinaire **HAL**, est destinée au dépôt et à la diffusion de documents scientifiques de niveau recherche, publiés ou non, émanant des établissements d'enseignement et de recherche français ou étrangers, des laboratoires publics ou privés.

The background image shows a person in silhouette on the left holding a tablet. In the foreground, a person with glasses is playing a flute. In the background, several digital avatars are visible, suggesting a virtual performance environment.

Empty Mind:

An exploration towards an autonomous digital experience and aesthetics
within a virtual live performance

End report for DARIAH-EU THEME 2020: Arts Exchanges
By Dr. Ine Vanoeveren and Kristof Timmerman



Table of contents

| | |
|--|----|
| 1. Background | 3 |
| 2. Lockdown Lobby | 3 |
| 3. studio.POC Lounge | 5 |
| 4. Virtual Academy & Conservatoire | 7 |
| 4.1 Fisherman's Lobby | 7 |
| 4.2 Cube Room | 8 |
| 4.3 Exhibition spaces of the Academy and Conservatoire | 9 |
| 4.4 Empty Mind Project (first stage) | 11 |
| 5. Empty Mind | 12 |
| 5.1 Platform and user interface | 12 |
| 5.2 Artistic data transfer | 13 |
| 5.3 Design | 13 |
| 5.4 Performance | 16 |
| 6. Technical set-up | 17 |
| 6.1 Audio equipment | 18 |
| 6.2 Mixing desk inputs | 18 |
| 6.3 Outputs | 18 |
| 7. Photos | 19 |
| 7.1 Photos from the livestream | 19 |
| 7.2 Photos from the premiere | 20 |
| 8. Future applications of the project | 21 |
| 9. Financial report | 23 |

1. Background

Numerous digital and virtual artistic initiatives have emerged over the past year, partly despite/thanks to the corona crisis. Digital art in a virtual environment mainly focuses on visual arts, whether in a digital twin environment or not. Only a few initiatives, such as [Area for Virtual Art](#) or [CIVA Festival](#) (both initiated by [sound:frame](#)), break with the known (digital) artistic reference frames, but they still underexpose the performing arts.

The research groups Maxlab and CREATIE have spent the past year studying these virtual initiatives and setting up their own digital co-creation experiments within a virtual environment. An example of this are the different rooms in Mozilla Hubs, where a variety of parameters were investigated: live performance, co-creation, interdisciplinarity within a digital context, digital experience, and dynamic interaction.

What follows in this first part of the report is a visual and conceptual description of these rooms, and a series of photographs as the witness of an immersive exploration in Mozilla Hubs.

2. Lockdown Lobby

The Lockdown Lobby originated as an initiative to break the routine in daily livestreams. Although the artistic world continued to spew livestream performances in March and April 2020, from May onwards it became quite annoying to stare at a YouTube or Vimeo interface yet again.

Originally this art lounge in Mozilla Hubs was a reaction to all those livestreams.

We wanted to bring an audience back together and let them collectively give their uncensored opinions on new creations and compositions via their avatars.

Each lockdown composition (collaborations between contemporary flutist Ine Vanoveren and several international composers) was presented in a customized setting in Mozilla Hubs – to digitally reinforce the musical narrative thanks to visual immersion in a virtual space.

But soon enough the space developed into a virtual lounge for digital art: 3D-models, digital scans, photos, and GIFs from researchers from Maxlab and CREATIE filled the Lobby.

In January 2021, we organized a virtual premiere party, presenting *Trumpet Vine*, a new composition by Jason Eckard for alto flute solo, with animations by Geoffa Fells.

Musical and artistic friends from all over the world were present, and for a moment we felt like we were at a premiere again. Eckardt received live compliments on his new composition, an experience he had to miss for almost a year because of those generic YouTube livestreams.

Even though a bad internet connection occasionally occurred, we concluded the evening with a virtual dance party to the tunes of YMCA. The combination with a festive gin-tonic made the experience complete and for a moment the craving for physical performances disappeared. Or at least for a very short while.

Visit the Lockdown Lobby [here](#) in Mozilla Hubs.

Concept, design and performance: Ine Vanoeveren

Compositions: Anahita Abbasi, Jason Eckardt, Geoffa Fells, Marcelo F. Lazcano, Frederik Neyrinck

Featured Artists: Janna Beck, Umut Eldem, Max Schweder, Kristof Timmerman

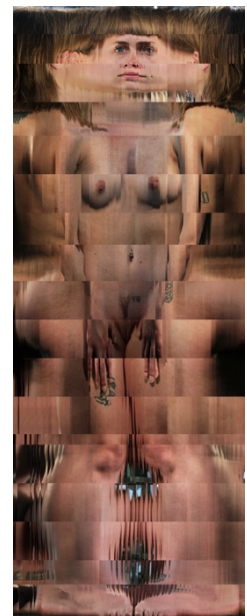
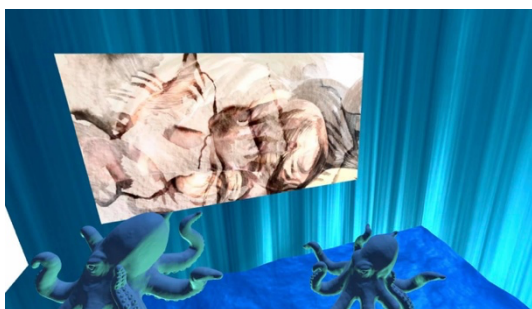
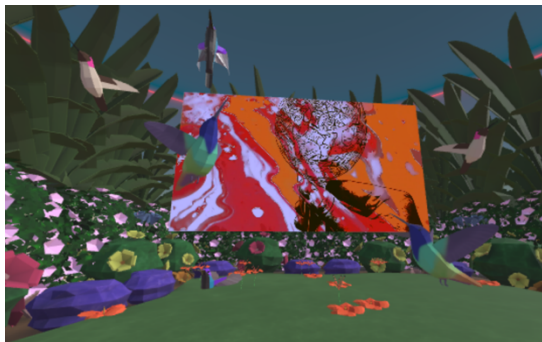

3. studio.POC Lounge

One aspect that was not highlighted within the development of the Lockdown Lobby was that of a digital live performance. Each work, each video, each performance can be viewed and experienced permanently, but they didn't have a public live premiere.

During NextDoors 2021, the annual interdisciplinary project week at the Royal Conservatoire Antwerp, studio.POC (digital arts collective of Kristof Timmerman and Ine Vanoeveren, amongst others) wanted to offer a digital alternative to students for their cancelled NextDoors festival. With the *Inclusiv/Exclusiv* project, the art activities normally on display *inside* campus deSingel, were now brought out into the open.

During this event, motion graphics and experimental videos were projected onto the *Immersive Cube*, including videos by students of deKunsthumaniora!

On the outside walls of deSingel people could experience live drawings and animations by students of the Royal Academy of Fine Arts Antwerp, in dialogue with a live performance by jazz students from the conservatoire.

The entire event was dynamically streamed into the virtual studio.POC Lounge.

In the physical world the conservatoire's jazz combo played at the entrance hall of deSingel, at the bottom of the stairs. In the virtual world, visitors could watch the energetic livestream all together on those same stairs. Avatars moved around the entire space, sometimes looking for a quieter spot to have a chat with a few friends. Thanks to the dynamic audio perception of Mozilla Hubs, avatars could 'walk away' for 10 virtual meters and have a chat without disturbing other visitors. During the event they could also visit Annelise Cerchedean's 3D exhibition.

In this way, the staircase of deSingel functioned as an artistic portal, with the live performance and the virtual livestream meeting each other on the same spot. The concept of the event was entirely focused on the livestream in the virtual environment, precisely because no audience was allowed to be physically present during the recordings. Therefore, the setup, flow and narrative were developed entirely from a digital perspective, making the virtual experience even more exciting and valuable than the physical event. Thanks to an autonomous digital aesthetics, livestreams in a virtual setting can give added value to a virtual audience.

Visit the studio.POC Lounge with the after movie of Inclusiv/Exclusiv [here](#) in Mozilla Hubs.

Room design: Max Schweder, Ine Vanoeveren

Virtual exhibition: Annelise Cerchedean

Livestream: Tom Dietvorst, Kristof Timmerman

Audio production: Jurgen Techel

Set-up and technique: Tom Dietvorst, Rik Suijs, Martine Thoné, Geert Van Impe

3D scanning: Annelise Cerchedean, Thomas Gladiné

After movie: Wes Nijssen

Coordination: Janna Beck, Kristof Timmerman, Ine Vanoeveren (studio.POC)

With the support of Lab101, BeamInc and the city of Antwerp

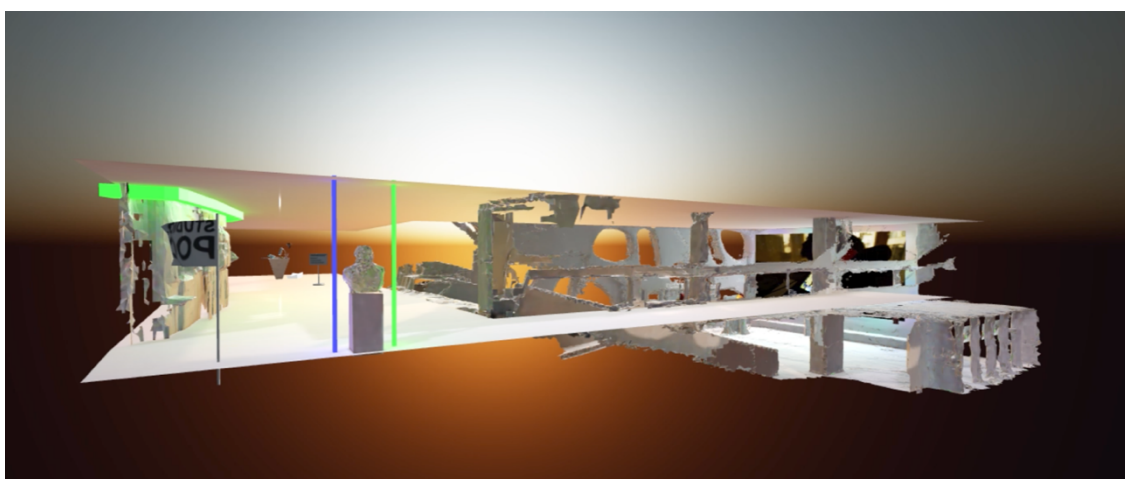
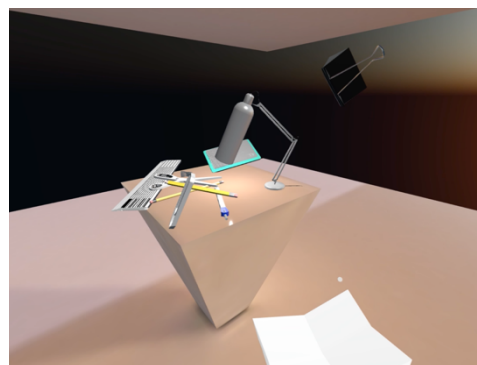
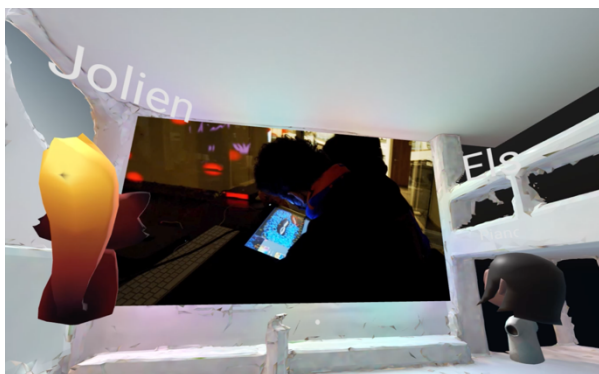
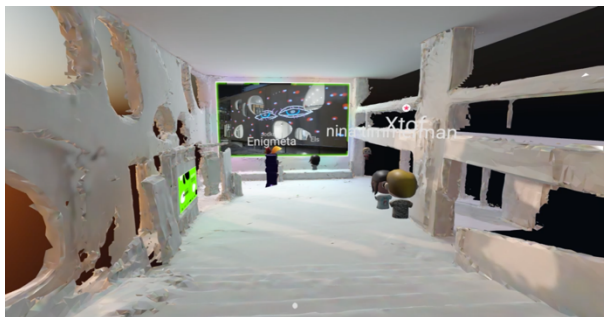

4. Virtual Academy & Conservatoire

The open house day of the Royal Academy of Fine Arts and the Royal Conservatoire Antwerp knew yet another digital version in 2021. During the first lockdown in April 2020, the open house day was quickly organized through Zoom and a chat box. Now, one year later, that bar had to be raised. The research groups Maxlab and CREATIE developed virtual spaces in Mozilla Hubs, which allowed future students to still experience a small part of that specific vibe of both art schools.

Students, dressed as host-avatar, were present to answer all the pressing questions of our next generation of students. Visitors were welcomed in the Fisherman's Lobby - a lobby that was designed by transforming a classical statue from the Academy into a low-poly giant. This lobby is a mashup of the Academy and the Conservatoire buildings, augmented with digital experiences.

4.1 Fisherman's Lobby

Here is the story of the Royal Fisherman, who went fishing to clear his mind and fill it with new ideas. He tries to capture these ideas in the Royal Conservatory of Antwerp and the Royal Academy of Antwerp ...

In addition to being a general meeting place, the Fisherman's Lobby is also a display of the different features and options within Mozilla Hubs. For example, there is a film with output from researchers from Maxlab and CREATIE that is being played in a constant loop. The audio can only be heard from within a limited radius around the screen, leaving enough space to communicate with each other.

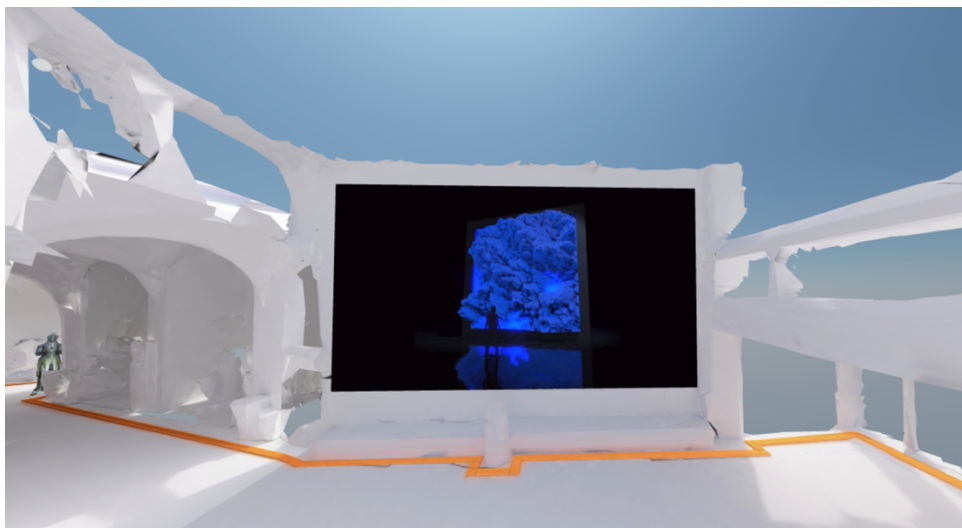

A little further down the corridors of the Academy, a statue is reciting *Vers 6* by Paul Van Ostaijen, with the voice of poet Philip Meersman. The statue is made of 2 transparent png's placed perpendicular to each other. Via Soundcloud the statue 'recites' in a constant loop.

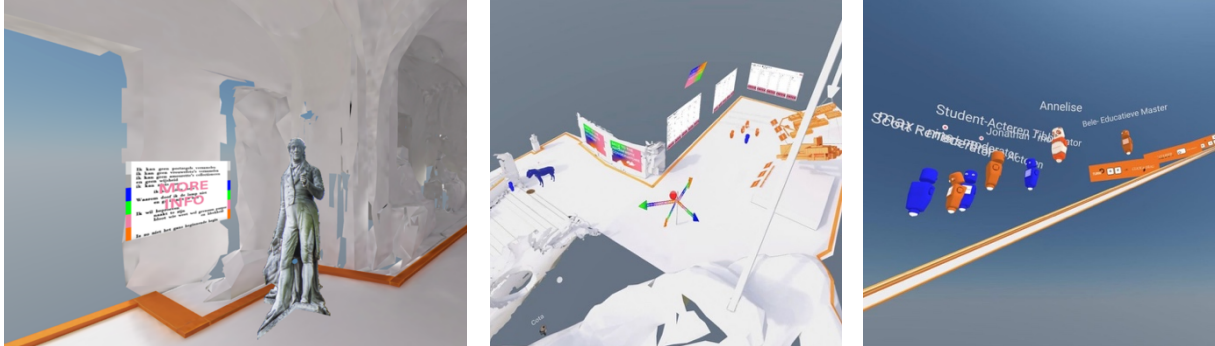

4.2 Cube Room

The orange lines delineate the route that visitors can follow, to explore all the rooms and installations. On the main statue is a large orange cube - the digital portal to the *Cube Room*. This room is the virtual twin of the *Immersive Cube*, a 3mx3mx3m cube, where images and animations can be projected along each side. Visitors can enter this cube, which means they are surrounded by digital projections. The same goes for the virtual cube in the Cube Room, where an immersive experience is being virtually recreated.

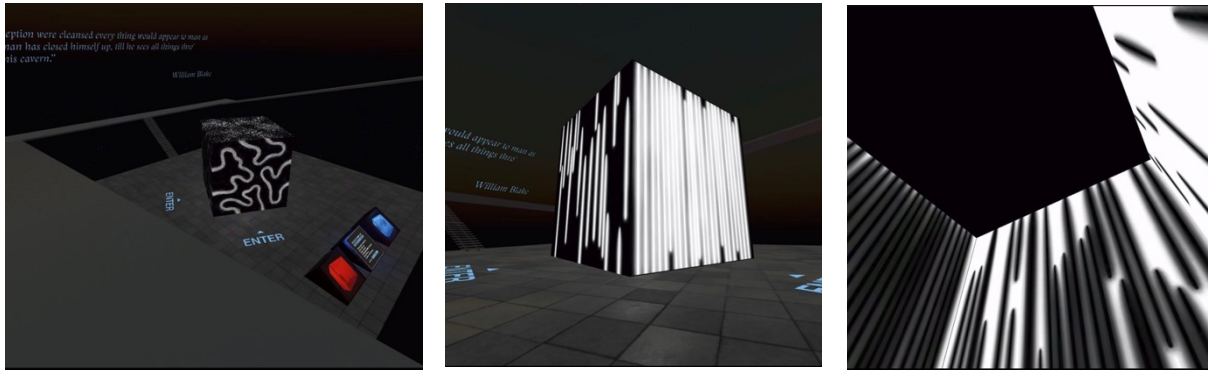

4.3 Exhibition spaces of the Academy and the Conservatoire

In addition to the Cube Room, visitors can also discover 2 other exhibition spaces. Both the Academy and the Conservatoire were given a virtual equivalent for the occasion, where prospective students and visitors could get an insight into the artistic process of both schools. Through the 3D models in the Fisherman's Lobby, visitors end up in the respective exhibition rooms.

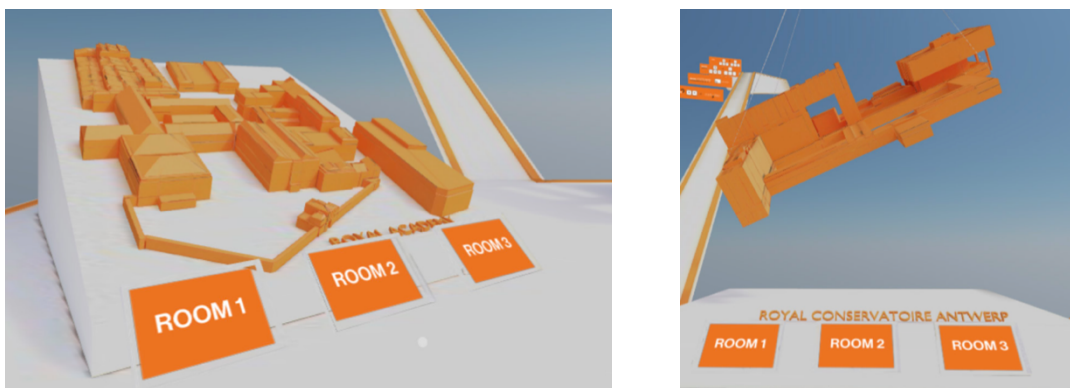

At the Academy, the garden and the *Lange Zaal* were virtually cloned. The garden features an exhibition of the various Instagram accounts of the Academy's programs, while the Lange Zaal is a motley collection of student works. Clickable GIFs bring visitors to an external webpage via a new tab, with the explanation and full video of the artworks. This makes it possible for visitors to look at a particular artwork together and still be able to talk to each other through the Mozilla Hubs space.

The Conservatoire is virtually represented through the iconic entrance of deSingel, where each of the various programs has been allocated their own corner. Visitors can walk from Jazz to Dance, via Classical Music and Drama. The same system of clickable GIFs is being used, so that visitors can enjoy a performance together and still keep in touch with each other in the Mozilla room.

The garden of deSingel has been transformed into a *Listening Garden* with podcasts by students of Word Art.

Both schools have their own 3D modeled and animated sculptures: a fuchsia two-headed horse for the Academy and several neon green chickens in the garden of the Conservatoire. At the Fisherman's Lobby, there is a flying a dragon. All of these objects were created by Jonathan Labiche.

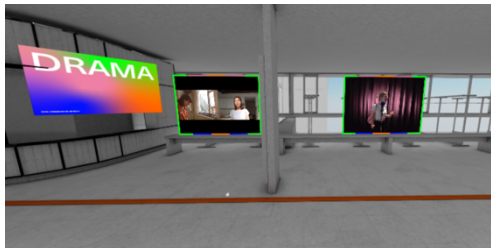
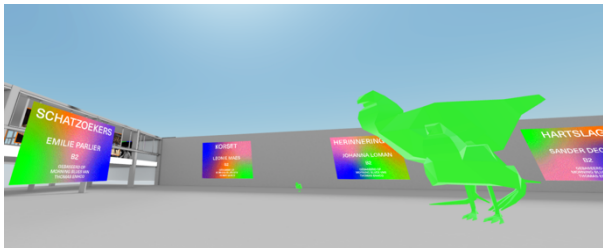
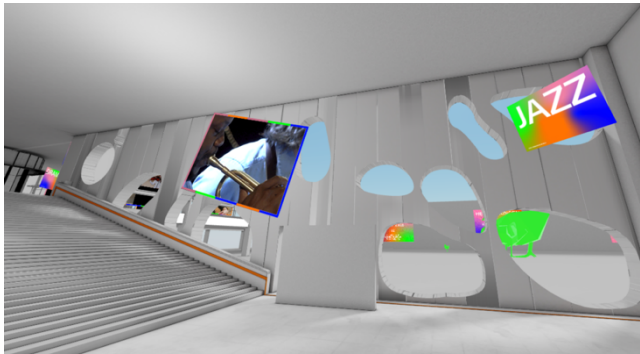
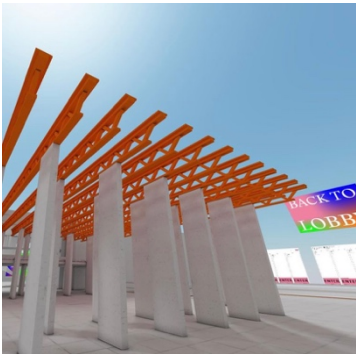
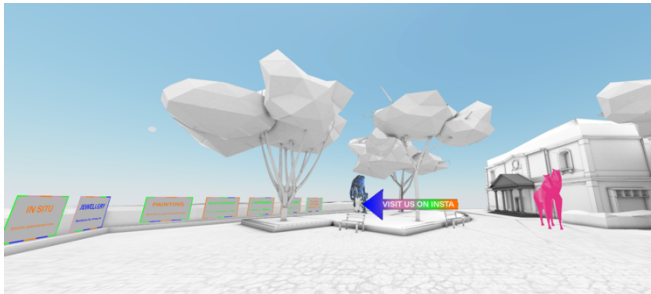
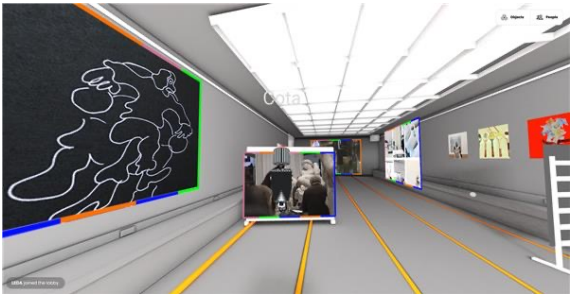
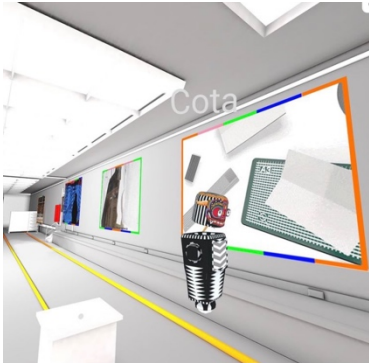

4.4 Empty Mind Project (first stage)

Finally, we return to the Fisherman's Lobby. Inside the empty head of the Royal Fisherman is a digital installation, as part of the Empty Mind Project. A first step in this project is this virtual installation, where a 360° video is being placed inside the empty head of the main statue.

As with the big screen and the poetic statue, sound has been added within a very limited perimeter. Visitors must enter the head to hear the music - a live recording of the work for flute solo, "No I am not roaming aimlessly" by Iranian composer Anahita Abbasi. This composition is based on two different ideologies: Dialogical Self Theory and Sufism. Dialogical Self Theory interweaves two concepts, 'self' and 'dialogue', in such a way that a deeper understanding of the interconnection of 'self' and society is achieved. The basis of this work is the English translation of a poem by Rumi.

While surrounded by the music, visitors can step into the 360° video. Once inside this strange sphere, the visitor is being surrounded by a desolate, mystical landscape. In this way, both the image and the music create an immersive experience for the visitor, reinforcing the emotional narrative of the work in a multisensorial way.



Concept & Design | Schools of Arts

Janna Beck, Annelise Cerchedean, Thomas Gladiné, Jonathan Labiche, Max Schweder, Kristof Timmerman, Ine Vanoeveren

External Development & Design

Roman Senkl, Nils Corte, Nils Gallist, Armin Luschin

Visit the Fisherman's Lobby in Mozilla Hubs [here](#) for the full experience, or go directly to one of the exhibition spaces: [Academy](#), [Conservatoire](#), [Cube Room](#).

5. Empty Mind

Empty Mind is an audiovisual live performance that takes place in a virtual environment and is meant to be viewed online. It is inspired by the works and ideas of the American artist Agnes Martin. The work consists of 6 large movements (5 + 1), which can be performed in any order. The spectator decides this order and can interfere with the performance through an interactive UI-layer on top of a livestream.

Originally, Empty Mind is a composition by Wim Henderickx for flutes (piccolo, flute, alto flute and bass flute) and live electronics. In each movement there is a strictly composed passage that represents a continuity between the parts and several free passages where the piece has the space and freedom to develop on its own - chosen by the soloist at that moment - creating a discontinuity.

Flutist Ine Vanoveren performs in a motion capture suit with which she controls the virtual environment. The performance in the virtual spaces is being filmed by a handheld, virtual camera and directly streamed onto Twitch. This livestream is the live feed for the audience, with the interactive layer on top of the video.

The audience is able to interact live with the performance by moving their mouses over the screen. This way they can alter the virtual environment and collectively decide the order of the movements. They can also throw live 3D emoji into the virtual environments.

The project premiered on October 28th ,2021, during the research festival ARTICULATE at the Wintertuin of the Royal Academy for Fine Arts Antwerp, Belgium.

The experience and knowledge we have obtained during our complete research trajectory led to the creation of our own platform and user interface for interactive virtual performances. The development for this project was focused on 4 domains: Platform and user interface, artistic data transfer, design and performance.

5.1 Platform and user interface

Audiences can react and interfere with the performance through an interactive UI-layer on top of a livestream. The composition Empty Mind exists of 6 movements.

The audience can choose the order of the movements by engaging with floating 3D-objects. Each movement is being represented by a 3D-object, derived from its according virtual room. Using a digital heat map, we can track the mouse positions of the audience and analyze which 3D-objects contain the most mouse positions, which will become the next movement within the performance. Audiences can also follow their own movement traces on their screen, interact with the virtual environment and send reactions to the performer: a set of emoji-buttons throws out 3D-emoji into the virtual space.

The performance in the virtual spaces is being filmed by a virtual camera (a 3D tracked iPad that displays a live rendering of the virtual scene from its current viewpoint) and directly streamed onto Twitch. This livestream is the live feed for the audience, with the interactive layer on top of the video.

5.2 Artistic data transfer

The movements of the performer are being tracked with a Rokoko motion capture suit and Rokoko Smart Gloves. The motion data is then being transferred into a Unity-3D environment, linking it to specific interactions, such as movement of geometric figures, color changes and avatar movements. The sound - dry flute signal and fx signal - is being integrated by a PureData-patch into Unity and has also real-time influence on the virtual environment.

Sound and movement thus co-create the virtual environment that has been predesigned within Unity.

5.3 Design

Wim Henderickx, the composer of Empty Mind, was inspired by the geometric figures of the American painter Agnes Martin and how she creates discretion on inward-ness and silence. The virtual rooms are being influenced by her paintings, without recreating a literal digital translation of her legacy.

Each room is being based on a certain geometric figure or algorithmic movement. The movement and audio data of the performer interact with the idiosyncratic behavior of these figures.

The performer is being represented by several, abstract avatars. The avatars have a different role in each movement: they blend into the surroundings, are being composed of building stones from the room or are an entity on their own.

Part 1: Awakening (flute)

Awakening, the call to dawn; subtle differences in color; microtonality portrays pain and discomfort

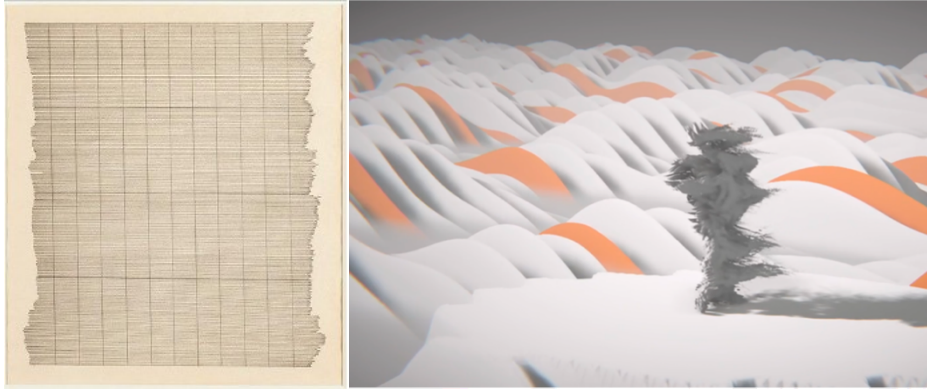

Part 2: Without desires (alto flute)

Concrete melodies are being veiled by the alto flute's shrouded sound; quarter tones make it alienate and provide subtle and brilliant color differences.

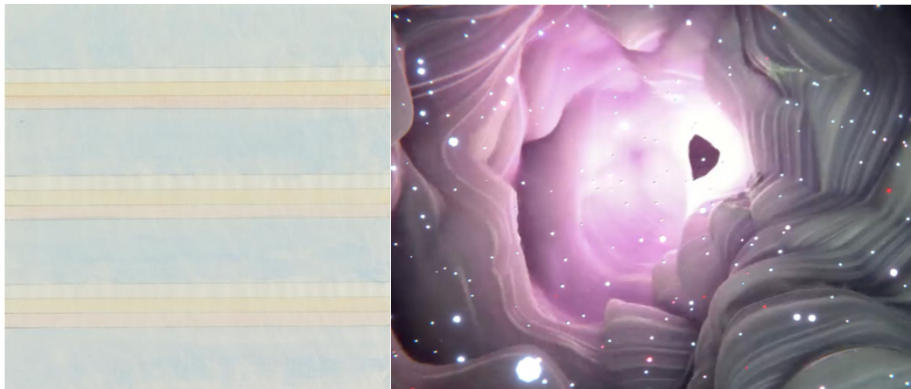

Part 3: Ecstasy (piccolo)

Virtuoso part, in the high register; is energetic, with fast passages and greater contrasts.

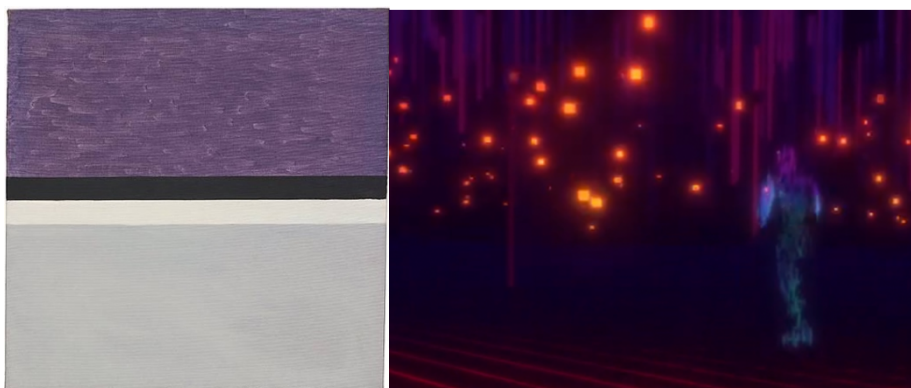

Part 4: Contemplation (bass flute).

Octavers in the electronics make the whole sound 2 octaves lower, with an emphasis on the basses; rhythmic 'calling' via same pattern is repeated, monolithic structure.

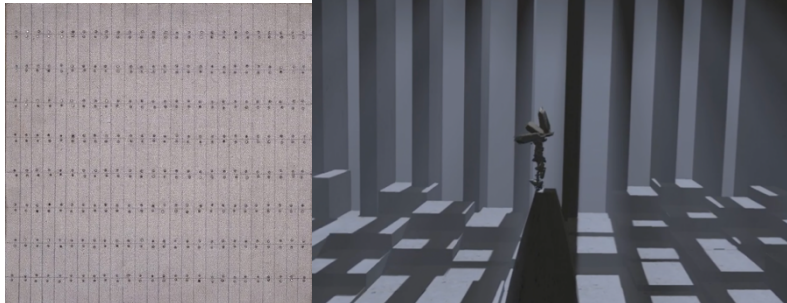

Part 5: Secret glance (flute)

Insistent melody, compelling colors, and structure; balance between tension (microtones) and relaxation (trills).

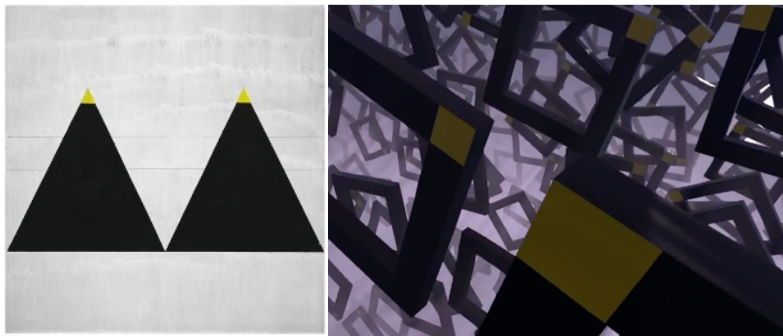

Part 6: Coda: Realization (flute)

Intimate and fragile, turned inwards; acceptance, pain.



5.4 Performance

Throughout the research proceeding this creation, the function and perception of a 'traditional' live performance has been questioned and investigated. The focus lies on the virtual experience, while the live performance is just a mere facilitator.

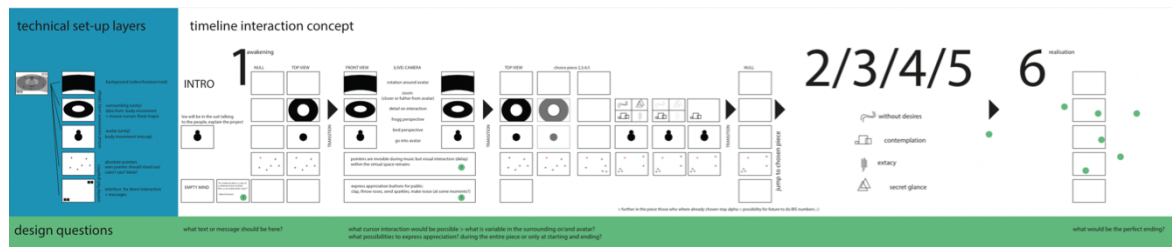

Where in a traditional, musical monodrama the communication of different parameters is aligned and consistent, the virtual monodrama functions differently. Movement and theatrical elements are not in support of the musical phrasing anymore, instead they create a different story in another universe, where the musical elements are both building blocks as well as strange passengers. The scenography and direction of Empty Mind is being established on the virtual appearance, treating the physical performance as a minor priority. However, the correlation between the physical acts and the virtual result are an interesting dichotomy between consistent communication, mono-dramatical phrasing and digital autonomy.

Team: Kristof Timmerman (concept and artistic direction), Ine Vanoeveren (concept and performer), Max Schweder (technical director, digital art), Wim Henderickx (composer, live electronics), Janna Beck (graphic design), Studio Plankton (3D graphic design), Naoto Hieda & Kristof Overdulve (platform & UI development), Lowie Spriet, Olivier Du Four & Arafa Yoncalik (development assistance), Wes Nijssen (assistance Motion Capturing), Tom Dietvorst (livestream, tech support), Jorrit Tamminga (live electronics), Umut Eldem (live electronics), Annelise Cerchedean (after movie)

This project is the start of 'Sense of Wonder', the joint research project of MAXlab (Royal Academy of Fine Arts, Antwerp, Belgium) and CREATIE (Royal Conservatoire Antwerp, Belgium).

With support of the Immersive Lab of AP University of Applied Sciences and Arts and Prof. Dr. Jouke Verlinden (Product Development, University of Antwerp).

You can find the after movie of the performance [here](#).

A technical after movie/tutorial is being made and will become public soon.

6. Technical set-up

3 monitor-screens

4 speakers

interface 18i20

interface 2i2

interface for livestream

mixing table

headset for flute

beamer

mocap + gloves

powerbanks

5G-hub

Virtual camera/iPad

camera for livestream

Visual + LAN Setup

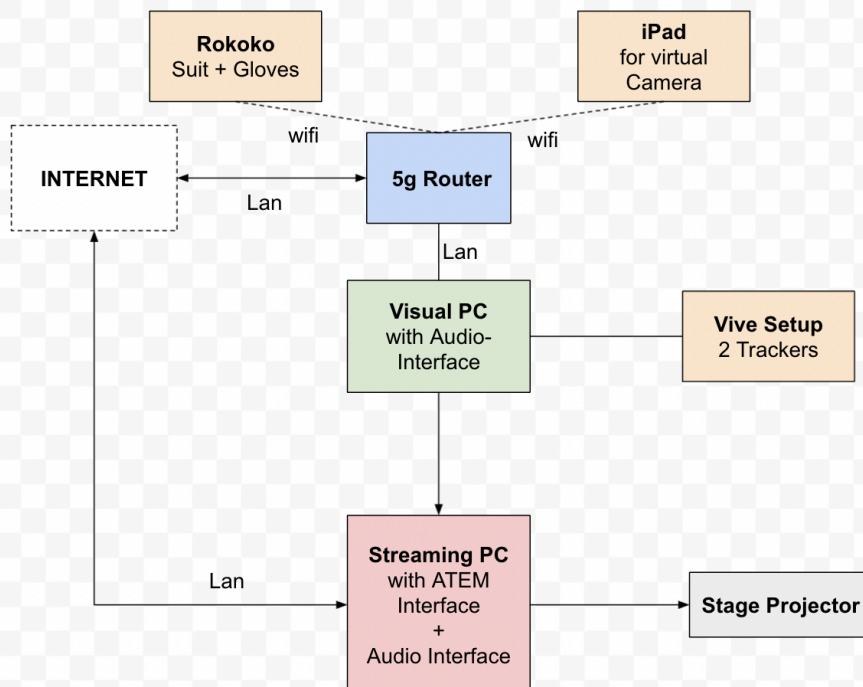

6.1 Audio equipment

- Microphone (*wireless if possible*)
- Mixing desk
- Reverb unit (*can be an internal effect from the mixing desk*)
- Speakers (*2 or more*)
- Subwoofer (*optional*)
- Soundcard FX (*1 input, 2 or more outputs (as many as the speakers)*) • Laptop 1 (*running the SuperCollider software FX*)
- Laptop 2 (*running the visuals*)

6.2 Mixing Desk Inputs

1. microphone input (for the solo instrument)
 - EQ
 - compressor
 - send 1 pre fader (post EQ/compressor) to soundcard laptop 1
 - send 2 post fader to reverb (internal or external)
 - send 3 pre fader to soundcard laptop 2 (channel 1)
2. soundcard output (2 or more channels)
 - send 4 (mono) pre fader to laptop 2 channel 2
3. reverb return (internal or external)

6.3 Outputs

1. Outputs to speakers (2 or more) (*subwoofer separate output if possible*) • The signal to the speakers can be the same as the signal to the live stream
2. Send 1 to soundcard laptop 1
3. Send 3 to soundcard laptop 2 (channel 1)
4. Send 4 to soundcard laptop (channel 2)

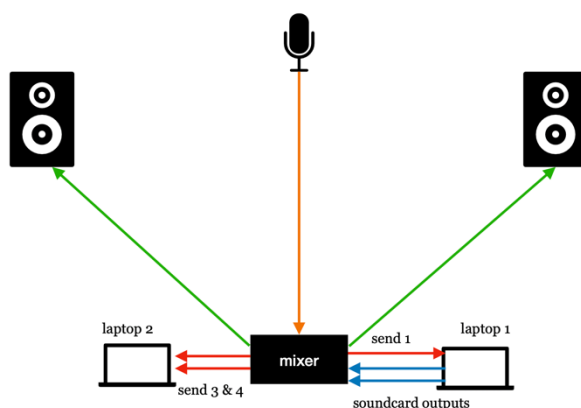

Audio Setup

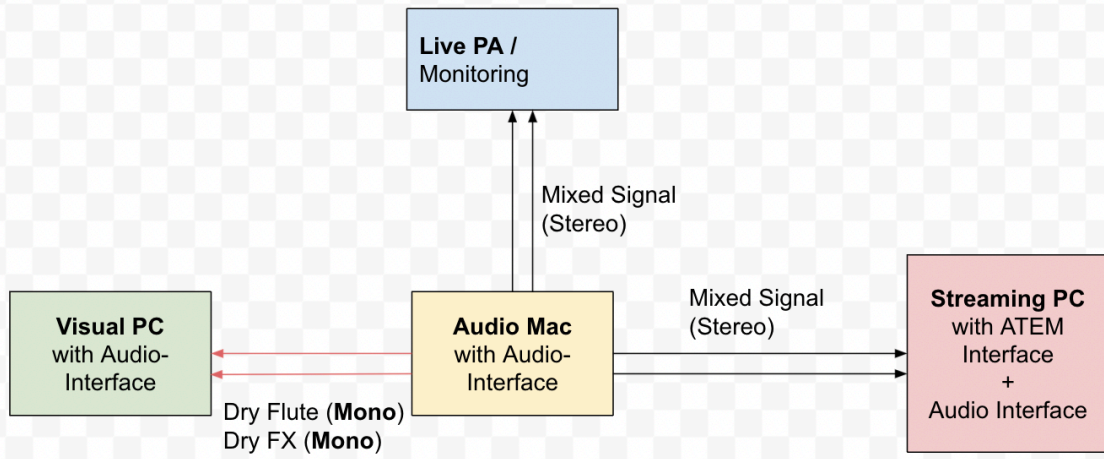

7. Photos

7.1 Photos from the livestream

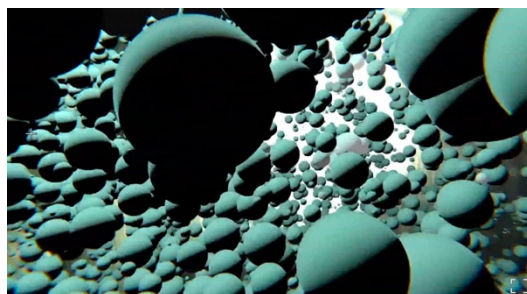
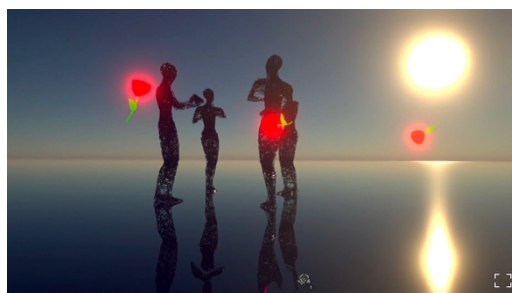
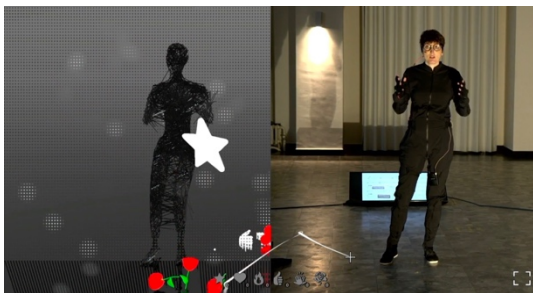

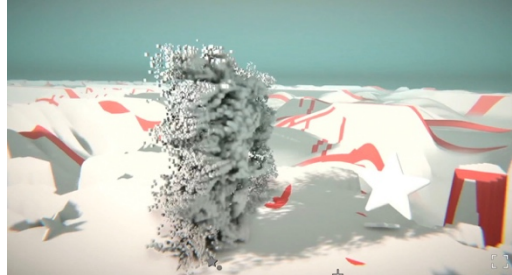
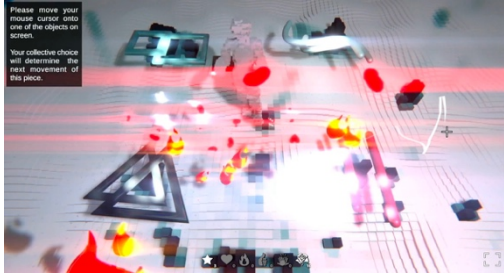
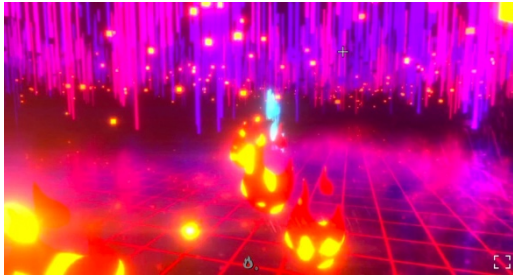

7.2 Photos from the première

Photo credit: Jayne Nattida Kanyachalao



8. Future applications of the project

Since the virtual premiere on October 28th, 2021, we have presented Empty Mind as a performance piece as well, where a live audience experiences the direct relation between the physical performance and the abstract technological translation. As a performance piece, a large screen (if possible, an immersive set-up) is being placed behind the flutist, who uses the whole stage as a performance space. In this way, the audience can relate the live performer to the avatar and everchanging virtual surroundings, and vice versa.

Performances:

November 4th: Opening concert of the AEC conference 2021 at deSingel, Antwerp.

November 8th: Festive opening of the Immersive Lab, AP University College of Applied Sciences and Arts, Antwerp.

November 15th: Television shoot for Atlas, NPO2 – Dutch television.

Conclusions and developments

We have noticed that a complete virtual live performance demands quite some empathy and imagination from the audience. We started the virtual performance with a split screen, where the audience both saw the flutist and the avatar, to establish the live connection between both. Further on in the performance, we never showed that relation again. For further performances, we will occasionally return to a split screen, to emphasize the liveness and to give the virtual audience a reminder of the relation between the avatar and the live performer.

Live interaction of a virtual audience turned out to be an important aspect of the flow of the performance. In between the different scenes/movements, we returned to a menu screen, where an avatar was guiding the audience on how to choose the next chapter in the performance. Because of a possible delay in the livestream on Twitch, the flutist needed to take the time to talk to the audience and wait for the democratic results of the choices. Although we expected these moments to break the flow of the performance, it turned out to be a necessary and successful component to engage the audience. A technical flaw caused the heatmap to malfunction, but it was still possible to engage the audience within the trajectory and storytelling of the performance.

Another part of interactivity was the live use of 3D emoji. The day of the performance, we decided to limit the number of emoji per person, since every 3D emoji adds extra data into the Unity scenes. It turned out to be a fortunate

decision, because people took every opportunity they had to throw us these emoji. The amount was even still too high. It didn't break the Unity scenes, but at some moments the virtual worlds were flooded with emoji. For our next performance, will limit them even more, so the interaction becomes a magical moment in the performance, and not a constant possibility.

The use of browser-based platforms is a risk and implies certain decisions and technical solutions. But it remains the most approachable way to engage an audience within a virtual environment today.

A next step will be the implementation of VR glasses, but as a first step, that would have excluded and/or scared a lot of people. The shift towards a hybrid lifestyle, where one can experience both live performances and events as well as virtual art, is fragile process that needs to be treated with care and consideration. Both the cultural organizations (CCS) as an audience are not ready yet to make a radical change. There is a general fear that virtuality would replace physical events, while we are strong advocates for an extra digital layer within the different experiences and formats of cultural activities.

The results and findings we gathered from our research trajectory will be shared as good practices during the upcoming brainstorm sessions of 'Voices of Culture, (Re)engaging Digital Audiences in the Cultural Sectors - Improving Audience Data', a dialogue between the European Commission and the cultural sector.

We have been selected as one of the 35 participants establishing and delivering guidelines to the European Commission regarding this topic.

We will use this performance of Empty Mind as a starting point and example for the future development of virtual live performances and artistic interventions within the metaverse. Engagement and live interaction play a big role, but also artistic and creative imagination will make a difference in a virtual, hybrid or augmented setting. The fact that Empty Mind was not a literal translation of the physical performance adds extra dimensions to the experience and immersion of a virtual live event. It functions as a door to an extra dimension, rather than a copy of reference frames we already explored in a physical setting.

9. Financial report

A complete financial report is being sent separately, together with the invoices in PDF-format. In this section we will explain any additional costs and/or changes.

The whole research process for Empty Mind ended up being a much bigger project than initially intended. Opportunities and new findings paved our trajectory; collaborators were so enthusiastic that the final performance has features we had not foreseen a year ago. We have found additional funding and used our own research budgets to cover these additional developments.

Lockdown Lobby

- no additional costs – within the research project of Ine Vanoeveren – 20% FTE

studio.POC Lounge

external funding from the city of Antwerp: 8000€

development of the virtual space, rent of the Immersive Cube, making of an after movie, livestream

Virtual Academy & Conservatoire

development of 4 virtual spaces

- budget of CREATIE: 2500€

- budget of Maxlab: €2500

- budget of the Schools of Arts: 5000€

Empty Mind

- extra budget for the development of the 3D-environments by Studio Plankton and Max Schweder: 4840€ on the budget of CREATIE

- personnel costs for Kristof Timmerman and Ine Vanoeveren: research project 'Sense of Wonder' – 20% FTE each

- purchase of a Focusrite Scarlet 18i20 audio-interface: 489€ - by studio.POC

- purchase of audio cables and extension cords: 220€ - by studio.POC

Note: within the development of the User Interface and virtual spaces in Unity, it became clear we needed the support of Max Schweder and Naoto Hieda because of their expertise in previous projects. This is why we had to schedule travel costs that were not initially foreseen in our budget proposal.