



**HAL**  
open science

## Detecting induced subgraphs

Benjamin Lévêque, David Y. Lin, Frédéric Maffray, Nicolas Trotignon

► **To cite this version:**

Benjamin Lévêque, David Y. Lin, Frédéric Maffray, Nicolas Trotignon. Detecting induced subgraphs. 2007. <halshs-00180953>

**HAL Id: halshs-00180953**

**<https://shs.hal.science/halshs-00180953v1>**

Submitted on 22 Oct 2007

HAL is a multi-disciplinary open access archive for the deposit and dissemination of scientific research documents, whether they are published or not. The documents may come from teaching and research institutions in France or abroad, or from public or private research centers.

L'archive ouverte pluridisciplinaire HAL, est destinée au dépôt et à la diffusion de documents scientifiques de niveau recherche, publiés ou non, émanant des établissements d'enseignement et de recherche français ou étrangers, des laboratoires publics ou privés.



Distributed under a Creative Commons CC BY 4.0 - Attribution - International License



# Documents de Travail du Centre d'Économie de la Sorbonne

C  
E  
S  
  
W  
o  
r  
k  
i  
n  
g  
  
P  
a  
p  
e  
r  
s

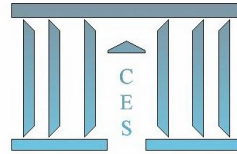

## Detecting induced subgraphs

Benjamin LEVEQUE, David Y. LIN,  
Frédéric MAFFRAY, Nicolas TROTIGNON

**2007.49**



CENTRE NATIONAL  
DE LA RECHERCHE  
SCIENTIFIQUE

# Detecting induced subgraphs

Benjamin Lévêque\*, David Y. Lin†, Frédéric Maffray\*, Nicolas Trotignon‡

October 9, 2007

## Abstract

An *s-graph* is a graph with two kinds of edges: *subdivisible* edges and *real* edges. A *realisation* of an *s-graph*  $B$  is any graph obtained by subdividing subdivisible edges of  $B$  into paths of arbitrary length (at least one). Given an *s-graph*  $B$ , we study the decision problem  $\Pi_B$  whose instance is a graph  $G$  and question is “Does  $G$  contain a realisation of  $B$  as an induced subgraph?”. For several  $B$ ’s, the complexity of  $\Pi_B$  is known and here we give the complexity for several more.

Our NP-completeness proofs for  $\Pi_B$ ’s rely on the NP-completeness proof of the following problem. Let  $\mathcal{S}$  be a set of graphs and  $d$  be an integer. Let  $\Gamma_{\mathcal{S}}^d$  be the problem whose instance is  $(G, x, y)$  where  $G$  is a graph whose maximum degree is at most  $d$ , with no induced subgraph in  $\mathcal{S}$  and  $x, y \in V(G)$  are two non-adjacent vertices of degree 2. The question is “Does  $G$  contain an induced cycle passing through  $x, y$ ?”. Among several results, we prove that  $\Gamma_{\emptyset}^3$  is NP-complete. We give a simple criterion on a connected graph  $H$  to decide whether  $\Gamma_{\{H\}}^{+\infty}$  is polynomial or NP-complete. On the other hand, the polynomial cases rely on the algorithm three-in-a-tree, due to Chudnovsky and Seymour.

**AMS Mathematics Subject Classification:** 05C85, 68R10, 68W05, 90C35

**Key words:** detecting, induced, subgraphs

## 1 Introduction

In this paper graphs are simple and finite. A *subdivisible graph* (*s-graph* for short) is a triple  $B = (V, D, F)$  such that  $(V, D \cup F)$  is a graph and  $D \cap F = \emptyset$ . The edges in  $D$  are said to be *real edges* of  $B$  while the edges in  $F$  are said to be *subdivisible edges* of  $B$ . A *realisation* of  $B$  is a graph obtained from  $B$  by subdividing edges of  $F$  into paths of arbitrary length (at least one). The problem

---

\*Laboratoire G-SCOP, 46 Avenue Félix Viallet, 38031 Grenoble Cedex, France. (benjamin.leveque@g-scop.inpg.fr, Frederic.Maffray@g-scop.inpg.fr)

†Princeton University, Princeton, NJ, 08544. dylin@princeton.edu

‡Université Paris I, Centre d’Économie de la Sorbonne, 106–112 boulevard de l’Hôpital, 75647 Paris cedex 13, France. nicolas.trotignon@univ-paris1.fr

This work has been partially supported by ADONET network, a Marie Curie training network of the European Community.

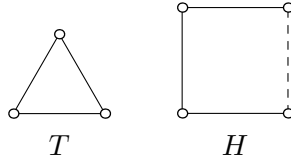

Figure 1: s-graphs yielding trivially polynomial problems

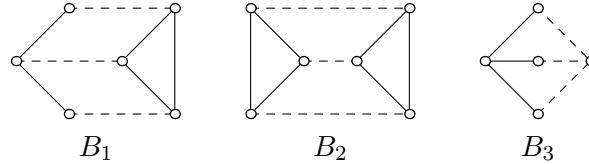

Figure 2: Pyramids, prisms and thetas

$\Pi_B$  is the decision problem whose input is a graph  $G$  and whose question is "Does  $G$  contain a realisation of  $B$  as an induced subgraph?". On figures, we depict real edges of an s-graph with straight lines, and subdivisible edges with dashed lines.

Several interesting instance of  $\Pi_B$  are studied in the litterature. For some of them, the existence of a polynomial time algorithm is trivial, but efforts are devoted toward optimized algorithms. For example, Alon, Yuster and Zwick [2] solve  $\Pi_T$  in time  $O(m^{1.41})$  (instead of the obvious  $O(n^3)$  algorithm), where  $T$  is the s-graph depicted on Figure 1. This problem is known as *triangle detection*. Tarjan and Yannakakis [10] solve  $\Pi_H$  in time  $O(n + m)$  where  $H$  is the s-graph depicted on Figure 1.

For some  $\Pi_B$ 's, the existence of a polynomial time algorithm is non-trivial. A *pyramid* (resp. *prism*, *theta*) is any realisation of the s-graph  $B_1$  (resp.  $B_2$ ,  $B_3$ ) depicted on figure 2. Chudnovsky and Seymour [5] gave an  $O(n^9)$ -time algorithm for  $\Pi_{B_1}$  (or equivalently, for detecting a pyramid). As far as we know, that is the first example of a solution to a  $\Pi_B$  whose complexity is non-trivial to settle. In contrast, Maffray and Trotignon [8] proved that  $\Pi_{B_2}$  (or detecting a prism) is NP-complete. Chudnovsky and Seymour [4] gave an  $O(n^{11})$ -time algorithm for  $P_{B_3}$  (or detecting a theta). Their algorithm relies on the solution of a problem called "three-in-a-tree", that we will define precisely and use in Section 2. The three-in-tree algorithm is quite general since it can be used to solve a lot of  $\Pi_B$  problems, including the detection of pyramids.

These facts are a motivation for a systematic study of  $\Pi_B$ . A further motivation is that very similar s-graphs can lead to a drastically different complexity. The following example may be more striking than pyramid/prism/theta :  $\Pi_{B_4}, \Pi_{B_6}$  are polynomial and  $\Pi_{B_5}, \Pi_{B_7}$  are NP-complete, where  $B_4, \dots, B_7$  are the s-graphs depicted on figure 3. This will be proved in section 3.1.

## Notation and remarks

By  $C_k$  ( $k \geq 3$ ) we denote the cycle on  $k$  vertices, by  $K_l$  ( $l \geq 1$ ) the clique on  $l$  vertices. We denote by  $I_l$  ( $l \geq 1$ ) the tree on  $l + 5$  vertices obtained by

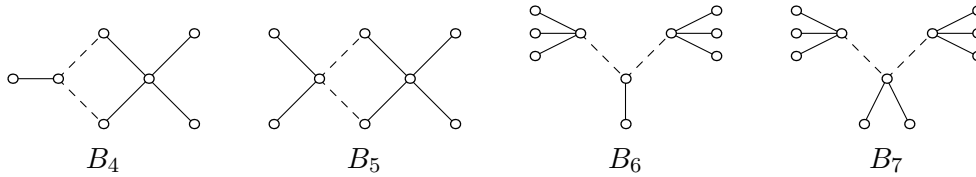

Figure 3: Some s-graphs with pending edges

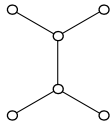

Figure 4:  $I_1$

taking a path of length  $l$  with ends  $a, b$ , and adding four vertices, two of them adjacent to  $a$ , the other two to  $b$ ; see Figure 4. When a graph  $G$  contains a graph isomorphic to  $H$  as an induced subgraph, we will often say “ $G$  contain an  $H$ ”.

Let  $(V, D, F)$  be an s-graph. Suppose that  $(V, D \cup F)$  has a vertex of degree one incident to an edge  $e$ . Then  $\Pi_{(V, D \cup \{e\}, F \setminus \{e\})}$  and  $\Pi_{(V, D \setminus \{e\}, F \cup \{e\})}$  have the same complexity, because a graph  $G$  contains a realisation of  $(V, D \cup \{e\}, F \setminus \{e\})$  if and only if it contains a realisation of  $(V, D \setminus \{e\}, F \cup \{e\})$ . For the same reason, if  $(V, D \cup F)$  has a vertex of degree two incident to the edges  $e \neq f$  then  $\Pi_{(V, D \setminus \{e\} \cup \{f\}, F \setminus \{f\} \cup \{e\})}$ ,  $\Pi_{(V, D \setminus \{f\} \cup \{e\}, F \setminus \{e\} \cup \{f\})}$  and  $\Pi_{(V, D \setminus \{e, f\}, F \cup \{e, f\})}$  have the same complexity. If  $|F| \leq 1$  then  $\Pi_{(V, D, F)}$  is clearly polynomial. Thus in the rest of the paper, we will consider only s-graphs  $(V, D, F)$  such that:

- $|F| \geq 2$ ;
- no vertex of degree one is incident to an edge of  $F$ ;
- every induced path of  $(V, D \cup F)$  with all interior vertices of degree 2 and whose ends have degree  $\neq 2$  has at most one edge in  $F$ . Moreover, this edge is incident to an end of the path;
- every induced cycle with at most one vertex  $v$  of degree at least 3 in  $(V, D \cup F)$  has at most one edge in  $F$  and this edge is incident to  $v$  if  $v$  exists (if it does not then the cycle is a component of  $(V, D \cup F)$ ).

## 2 Detection of holes with prescribed vertices

Let  $\Delta(G)$  be the maximum degree of  $G$ . Let  $\mathcal{S}$  be a set of graphs and  $d$  be an integer. Let  $\Gamma_{\mathcal{S}}^d$  be the problem whose instance is  $(G, x, y)$  where  $G$  is a graph such that  $\Delta(G) \leq d$ , with no induced subgraph in  $\mathcal{S}$  and  $x, y \in V(G)$  are two non-adjacent vertices of degree 2. The question is “Does  $G$  contain a hole passing through  $x, y$ ?”. For simplicity, we write  $\Gamma_{\mathcal{S}}$  instead of  $\Gamma_{\mathcal{S}}^{+\infty}$  (so, the graph in the instance of  $\Gamma_{\mathcal{S}}$  has unbounded degree). Also we write  $\Gamma^d$  instead

of  $\Gamma_\emptyset^d$  (so the graph in the instance of  $\Gamma^d$  has no restriction on its induced subgraphs). Bienstock [3] proved that  $\Gamma = \Gamma_\emptyset$  is NP-complete. For  $\mathcal{S} = \{K_3\}$  and  $\mathcal{S} = \{K_{1,4}\}$ ,  $\Gamma_{\mathcal{S}}$  can be shown to be NP-complete, and a consequence is the NP-completeness of several problems of interest: see [8] and [9].

In this section, we try to settle  $\Gamma_{\mathcal{S}}^d$  for as many  $\mathcal{S}$ 's and  $d$ 's as we can. In particular, we give the complexity of  $\Gamma_{\mathcal{S}}$  when  $\mathcal{S}$  contains only one connected graph and of  $\Gamma^d$  for all  $d$ . We also settle  $\Gamma_{\mathcal{S}}^d$  for some cases when  $\mathcal{S}$  is a set of cycles. The polynomial cases are either trivial, or are a direct consequence of an algorithm of Chudnovsky and Seymour. The NP-complete cases follow from several extensions of Bienstock's construction.

## Polynomial cases

Chudnovsky and Seymour [4] proved that the problem whose instance is a graph and three vertices  $a, b, c$ , whose question is "Does the graph contains a tree passing through  $a, b, c$  as an induced subgraph?" can be solved in  $O(n^4)$ . We call this algorithm "three-in-a-tree". Three-in-a-tree can be used directly to solve  $\Gamma_{\mathcal{S}}$  for several  $\mathcal{S}$ 's. Let us call *subdivided claw* any tree with one vertex  $u$  of degree 3, three vertices  $v_1, v_2, v_3$  of degree 1 and all the other vertices of degree 2.

**Theorem 2.1** *Let  $H$  be a graph on  $k$  vertices that is either a path or a subdivided claw. There is an  $O(n^k)$ -time algorithm for  $\Gamma_{\{H\}}$ .*

PROOF — Here is an algorithm for  $\Gamma_{\{H\}}$ . Let  $(G, x, y)$  be an instance of  $\Gamma_H$ . If  $H$  is a path on  $k$  vertices then every hole in  $G$  is on at most  $k$  vertices. Hence, by a brute-force search on every  $k$ -tuple, we will find a hole through  $x, y$  if there is any. Now we suppose that  $H$  is a subdivided claw. So  $k \geq 4$ . For convenience, we put  $x_1 = x, y_1 = y$ . Let  $x_0, x_2$  (resp.  $y_0, y_2$ ) be the two neighbors of  $x_1$  (resp.  $y_1$ ).

First check whether there is in  $G$  a hole  $C$  through  $x_1, y_1$  such that the distance between  $x_1$  and  $y_1$  in  $C$  is at most  $k - 2$ . If  $k = 4$  or  $k = 5$  then the vertex-set of any such hole must be included in  $\{x_0, x_1, x_2, y_0, y_1, y_2\}$ , so it can be found in constant time. Now suppose  $k \geq 6$ . For every  $l$ -tuple  $(x_3, \dots, x_{l+2})$  of vertices of  $G$ , with  $l \leq k - 5$ , test whether  $P = x_0 - x_1 - \dots - x_{l+2} - y_2 - y_1 - y_0$  is an induced path, and if so delete the interior vertices of  $P$  and their neighbors except  $x_0, y_0$ , and look for a shortest path from  $x_0$  to  $y_0$ . This will find the desired hole if there is one, after possibly swapping  $x_0, x_2$  and doing the work again. This takes time  $O(n^{k-3})$ .

Now we assume that in every hole through  $x_1, y_1$ , the distance between  $x_1, y_1$  is at least  $k - 1$ .

Let  $k_i$  be the length of the unique path of  $H$  from  $u$  to  $v_i$ ,  $i = 1, 2, 3$ . Note that  $k = k_1 + k_2 + k_3 + 1$ . Let us check every  $(k - 4)$ -tuple  $z = (x_3, \dots, x_{k_1+1}, y_3, \dots, y_{k_2+k_3})$  of vertices of  $G$ . For such a  $(k - 4)$ -tuple, test whether  $x_0 - x_1 - \dots - x_{k_1+1}$  and  $P = y_0 - y_1 - \dots - y_{k_2+k_3}$  are induced paths of  $G$  with no edge between them except possibly  $x_{k_1+1}y_{k_2+k_3}$ . If not, go to the next  $(k - 4)$ -tuple, but if yes, delete the interior vertices of  $P$  and their neighbors except  $y_0, y_{k_2+k_3}$ . Also delete the neighbors of  $x_2, \dots, x_{k_1}$ , except  $x_1, x_2, \dots, x_{k_1}, x_{k_1+1}$ . Call  $G_z$  the resulting graph and run three-in-a-tree in

$G_z$  for the vertices  $x_1, y_{k_2+k_3}, y_0$ . We claim that the answer to three-in-a-tree is YES for some  $(k-4)$ -tuple if and only if  $G$  contains a hole through  $x_1, y_1$  (after possibly swapping  $x_0, x_2$  and doing the work again).

If  $G$  contains a hole  $C$  through  $x_1, y_1$  then up to a symmetry this hole visits  $x_0, x_1, x_2, y_2, y_1, y_0$  in this order. Let us name  $x_3, \dots, x_{k_1+1}$  the vertices of  $C$  that follow after  $x_1, x_2$ , and let us name  $y_3, \dots, y_{k_2+k_3}$  those that follow after  $y_1, y_2$ . Note that all these vertices exist and are pairwise distinct since in every hole through  $x_1, y_1$  the distance between  $x_1, y_1$  is at least  $k-1$ . So the path from  $y_0$  to  $y_{k_2+k_3}$  in  $C \setminus y_1$  is a tree of  $G_z$  passing through  $x_1, y_{k_2+k_3}, y_0$ , where  $z$  is the  $(k-4)$ -tuple  $(x_3, \dots, x_{k_1+1}, y_3, \dots, y_{k_2+k_3})$ .

Conversely, suppose that  $G_z$  contains a tree  $T$  passing through  $x_1, y_{k_2+k_3}, y_0$ , for some  $(k-4)$ -tuple  $z$ . We suppose that  $T$  is vertex-inclusion-wise minimal. If  $T$  is a path visiting  $y_0, x_1, y_{k_2+k_3}$  in this order, then we obtain the desired hole of  $G$  by adding  $y_1, y_2, \dots, y_{k_2+k_3-1}$  to  $T$ . If  $T$  is a path visiting  $x_1, y_0, y_{k_2+k_3}$  in this order, then we denote by  $y_{k_2+k_3+1}$  the neighbor of  $y_{k_2+k_3}$  along  $T$ . Note that  $T$  contains either  $x_0$  or  $x_2$ . If  $T$  contains  $x_0$ , then there are three paths in  $G$ :  $y_0 - T - x_0 - x_1 - \dots - x_{k_1}$ ,  $y_0 - T - y_{k_2+k_3+1} - \dots - y_{k_3+2}$  and  $y_0 - y_1 - \dots - y_{k_3}$ . These three paths form a subdivided claw centered at  $y_0$  that is long enough to contain an induced subgraph isomorphic to  $H$ , a contradiction. If  $T$  contains  $x_2$  then the proof works similarly with  $y_0 - T - x_{k_1+1} - x_{k_1} - \dots - x_1$  instead of  $y_0 - T - x_0 - x_1 - \dots - x_{k_1}$ . If  $T$  is a path visiting  $x_1, y_{k_2+k_3}, y_0$  in this order, the proof is similar, except that we find a subdivided claw centered at  $y_{k_2+k_3}$ . If  $T$  is not a path, then it is a subdivided claw centered at a vertex  $u$  of  $G$ . We obtain again an induced subgraph of  $G$  isomorphic to  $H$  by adding to  $T$  sufficiently many vertices of  $\{x_0, \dots, x_{k_1+1}, y_0, \dots, y_{k_2+k_3}\}$ .  $\square$

## NP-complete cases (unbounded degree)

Many NP-completeness results can be proved by adapting Bienstock's construction. We give here several polynomial reductions from the problem 3-SATISFIABILITY of Boolean functions. These results are given in a framework that involves a few parameters, so that our result can possibly be used for other problems of the same type. Recall that a Boolean function with  $n$  variables is a mapping  $f$  from  $\{0, 1\}^n$  to  $\{0, 1\}$ . A Boolean vector  $\xi \in \{0, 1\}^n$  is a *truth assignment* for  $f$  if  $f(\xi) = 1$ . For any Boolean variable  $z$  on  $\{0, 1\}$ , we write  $\bar{z} := 1 - z$ , and each of  $z, \bar{z}$  is called a *literal*. An instance of 3-SATISFIABILITY is a Boolean function  $f$  given as a product of clauses, each clause being the Boolean sum  $\vee$  of three literals; the question is whether  $f$  admits a truth assignment. The NP-completeness of 3-SATISFIABILITY is a fundamental result in complexity theory, see [6].

Let  $f$  be an instance of 3-SATISFIABILITY, consisting of  $m$  clauses  $C_1, \dots, C_m$  on  $n$  variables  $z_1, \dots, z_n$ . For every integer  $k \geq 3$  and parameters  $\alpha \in \{1, 2\}$ ,  $\beta \in \{0, 1\}$ ,  $\gamma \in \{0, 1\}$ ,  $\delta \in \{0, 1, 2, 3\}$ ,  $\varepsilon \in \{0, 1\}$ ,  $\zeta \in \{0, 1\}$  such that if  $\alpha = 2$  then  $\varepsilon = \beta = \gamma$ , let us build a graph  $G_f(k, \alpha, \beta, \gamma, \delta, \varepsilon, \zeta)$  with two specialized vertices  $x, y$  of degree 2. There will be a hole containing  $x$  and  $y$  in  $G_f(k, \alpha, \beta, \gamma, \delta, \varepsilon, \zeta)$  if and only if there exists a truth assignment for  $f$ . In  $G_f(k, \alpha, \beta, \gamma, \delta, \varepsilon, \zeta)$  (we will sometimes write  $G_f$  for short), there will be two

kinds of edges: blue and red. The reason for this distinction will appear later.

For each variable  $z_i$  ( $i = 1, \dots, n$ ), prepare a graph  $G(z_i)$  with  $4k$  vertices  $a_{i,r}, b_{i,r}, a'_{i,r}, b'_{i,r}$ ,  $r \in \{1, \dots, k\}$  and  $4(m+2)2k$  vertices  $t_{i,2pk+r}, f_{i,2pk+r}, t'_{i,2pk+r}, f'_{i,2pk+r}$ ,  $p \in \{0, \dots, m+1\}$ ,  $r \in \{0, \dots, 2k-1\}$ . Add blue edges so that the four sets  $\{a_{i,1}, \dots, a_{i,k}, t_{i,0}, \dots, t_{i,2k(m+2)-1}, b_{i,1}, \dots, b_{i,k}\}$ ,  $\{a'_{i,1}, \dots, a'_{i,k}, f_{i,0}, \dots, f_{i,2k(m+2)-1}, b_{i,1}, \dots, b_{i,k}\}$ ,  $\{a'_{i,1}, \dots, a'_{i,k}, t'_{i,0}, \dots, t'_{i,2k(m+2)-1}, b'_{i,1}, \dots, b'_{i,k}\}$ ,  $\{a'_{i,1}, \dots, a'_{i,k}, f'_{i,0}, \dots, f'_{i,2k(m+2)-1}, b'_{i,1}, \dots, b'_{i,k}\}$  all induce paths (and the vertices appear in this order along these paths). See Figure 5.

Add red edges according to the value of  $\alpha, \beta, \gamma$ , as follows.

If  $\alpha = 1$  then, for every  $p = 1, \dots, m+1$ , add all edges between  $\{t_{i,2kp}, t_{i,2kp+\beta}\}$  and  $\{f_{i,2kp}, f_{i,2kp+\gamma}\}$ , between  $\{f_{i,2kp}, f_{i,2kp+\gamma}\}$  and  $\{t'_{i,2kp}, t'_{i,2kp+\beta}\}$ , between  $\{t'_{i,2kp}, t'_{i,2kp+\beta}\}$  and  $\{f'_{i,2kp}, f'_{i,2kp+\gamma}\}$ , between  $\{f'_{i,2kp}, f'_{i,2kp+\gamma}\}$  and  $\{t_{i,2kp}, t_{i,2kp+\beta}\}$ .

If  $\alpha = 2$  then, for every  $p = 1, \dots, m$ , add all edges between  $\{t_{i,2kp+k-1}, t_{i,2kp+k-1+\beta}\}$  and  $\{f_{i,2kp+k-1}, f_{i,2kp+k-1+\gamma}\}$ ; for every  $p = 1, \dots, m+1$ , add all edges between  $\{f_{i,2kp+k-1}, f_{i,2kp+k-1+\gamma}\}$  and  $\{t'_{i,2kp}, t'_{i,2kp+\beta}\}$ , between  $\{t'_{i,2kp}, t'_{i,2kp+\beta}\}$  and  $\{f'_{i,2kp}, f'_{i,2kp+\gamma}\}$ , between  $\{f'_{i,2kp}, f'_{i,2kp+\gamma}\}$  and  $\{t_{i,2k(p-1)+k-1}, t_{i,2k(p-1)+k-1+\beta}\}$ . See Figures 6, 7.

For each clause  $C_j$  ( $j = 1, \dots, m$ ), with  $C_j = y_j^1 \vee y_j^2 \vee y_j^3$ , where each  $y_j^q$  ( $q = 1, 2, 3$ ) is a literal from  $\{z_1, \dots, z_n, \bar{z}_1, \dots, \bar{z}_n\}$ , prepare a graph  $G(C_j)$  with  $2k$  vertices  $c_{j,p}, d_{j,p}$ ,  $p \in \{1, \dots, k\}$  and  $6k$  vertices  $u_{j,p}^q$ ,  $q \in \{1, 2, 3\}$ ,  $p \in \{1, \dots, 2k\}$ . Add blue edges so that the three sets  $\{c_{j,1}, \dots, c_{j,k}, u_{j,1}^q, \dots, u_{j,2k}^q, d_{j,1}, \dots, d_{j,k}\}$ ,  $q \in \{1, 2, 3\}$  all induce paths (and the vertices appear in this order along these paths). Add red edges according to the value of  $\delta$ . If  $\delta = 0$ , add no edge. If  $\delta = 1$ , add  $u_{j,1}^1 u_{j,1}^2, u_{j,2k}^1 u_{j,2k}^2$ . If  $\delta = 2$ , add  $u_{j,1}^1 u_{j,1}^2, u_{j,1}^1 u_{j,1}^3, u_{j,2k}^1 u_{j,2k}^2, u_{j,2k}^1 u_{j,2k}^3$ . If  $\delta = 3$ , add  $u_{j,1}^1 u_{j,1}^2, u_{j,1}^1 u_{j,1}^3, u_{j,2k}^1 u_{j,2k}^2, u_{j,2k}^1 u_{j,2k}^3$ . See Figure 8.

The graph  $G_f(k, \alpha, \beta, \gamma, \delta, \varepsilon, \zeta)$  is obtained from the disjoint union of the  $G(z_i)$ 's and the  $G(C_j)$ 's as follows. For  $i = 1, \dots, n-1$ , add blue edges  $b_{i,k} a_{i+1,1}$  and  $b'_{i,k} a'_{i+1,1}$ . Add a blue edge  $b'_{n,k} c_{1,1}$ . For  $j = 1, \dots, m-1$ , add a blue edge  $d_{j,k} c_{j+1,1}$ . Introduce the two special vertices  $x, y$  and add blue edges  $xa_{1,1}, xa'_{1,1}$  and  $yd_{m,k}, yb_{n,k}$ . See Figure 9.

Add red edges according to  $f, \varepsilon, \zeta$ . For  $q = 1, 2, 3$ , if  $y_j^q = z_i$ , then add all possible edges between  $\{f_{i,2kj+k-1}, f_{i,2kj+k-1+\varepsilon}\}$  and  $\{u_{j,k}^q, u_{j,k+\zeta}^q\}$  and between  $\{f'_{i,2kj+k-1}, f'_{i,2kj+k-1+\varepsilon}\}$  and  $\{u_{j,k}^q, u_{j,k+\zeta}^q\}$ ; while if  $y_j^q = \bar{z}_i$  then add all possible edges between  $\{t_{i,2kj+k-1}, t_{i,2kj+k-1+\varepsilon}\}$  and  $\{u_{j,k}^q, u_{j,k+\zeta}^q\}$  and between  $\{t'_{i,2kj+k-1}, t'_{i,2kj+k-1+\varepsilon}\}$  and  $\{u_{j,k}^q, u_{j,k+\zeta}^q\}$ . See Figure 10.

Clearly the size of  $G_f(k, \alpha, \beta, \gamma, \delta, \varepsilon, \zeta)$  is polynomial (actually quadratic) in the size  $n+m$  of  $f$ , and  $x, y$  are non-adjacent and both have degree two.

**Lemma 2.2**  *$f$  admits a truth assignment if and only if  $G_f(k, \alpha, \beta, \gamma, \delta, \varepsilon, \zeta)$  contains a hole passing through  $x, y$ .*

PROOF — Recall that if  $\alpha = 2$  then  $\varepsilon = \beta = \gamma$ . We will prove the lemma for  $\beta = 0, \gamma = 0, \varepsilon = 0, \zeta = 0$  because the proof is essentially the same for the other possible values.

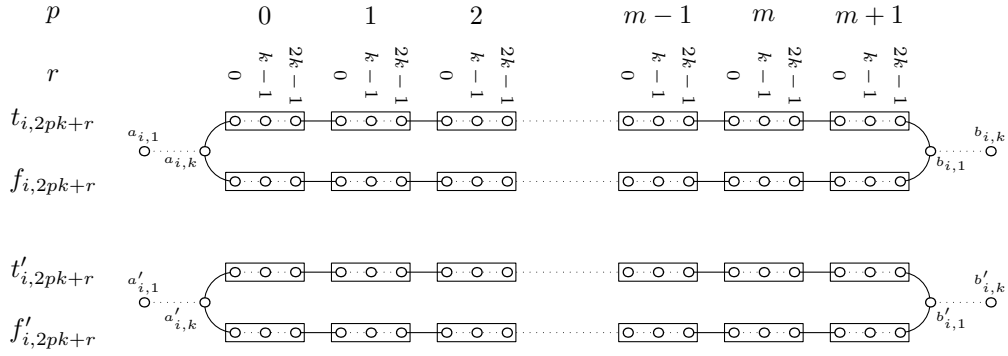

Figure 5: The graph  $G(z_i)$  (only blue edges are depicted)

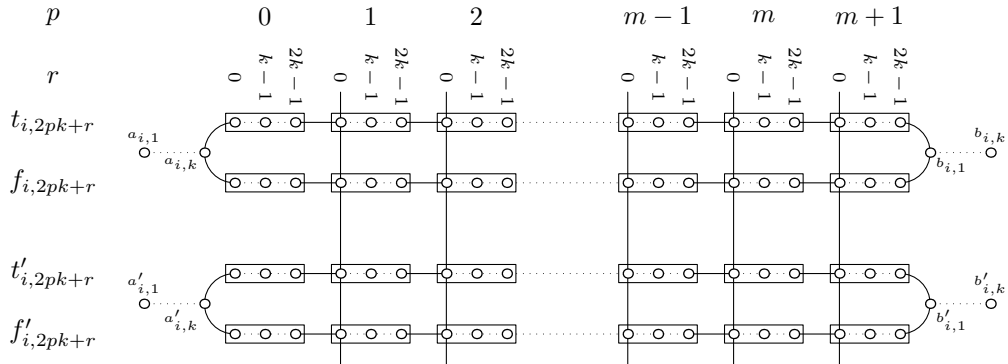

Figure 6: The graph  $G(z_i)$  when  $\alpha = 1, \beta = 0, \gamma = 0$

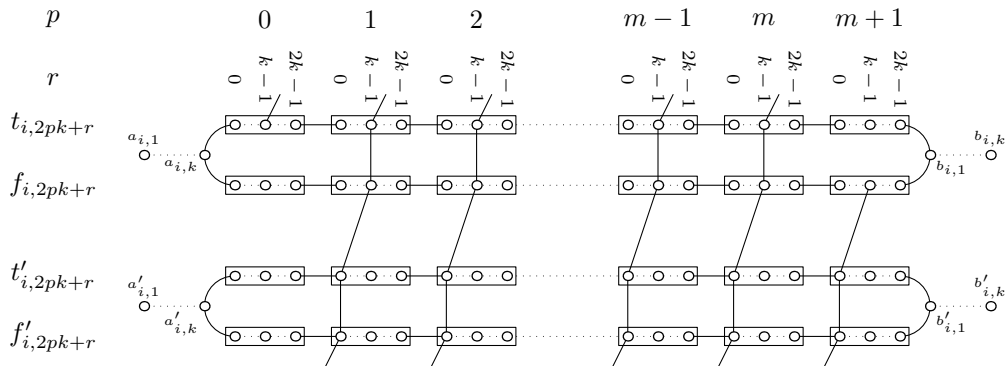

Figure 7: The graph  $G(z_i)$  when  $\alpha = 2, \beta = 0, \gamma = 0$

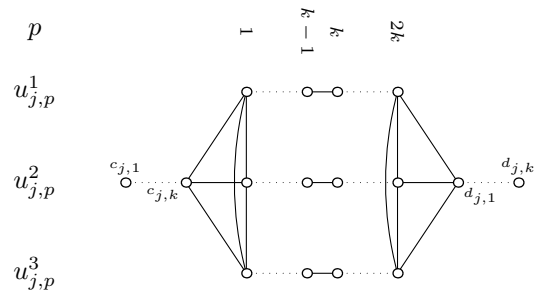

Figure 8: The graph  $G(c_j)$  when  $\delta = 3$

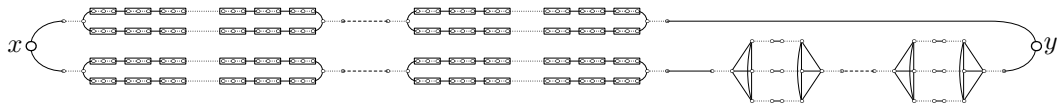

Figure 9: The whole graph  $G_f$

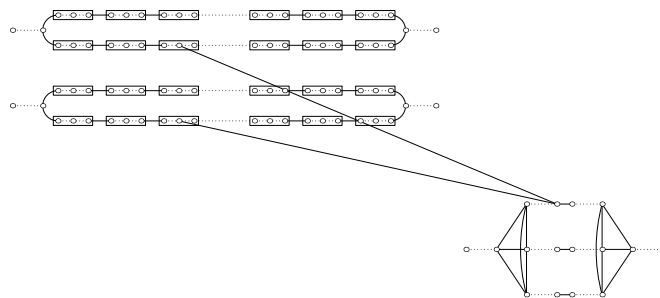

Figure 10: Red edges between  $G(z_i)$  and  $G(c_j)$  when  $\varepsilon = \zeta = 0$

Suppose that  $f$  admits a truth assignment  $\xi \in \{0, 1\}^n$ . We can build a hole in  $G$  by selecting vertices as follows. Select  $x, y$ . For  $i = 1, \dots, n$ , select  $a_{i,p}, b_{i,p}, a'_{i,p}, b'_{i,p}$  for all  $p \in \{1, \dots, k\}$ . For  $j = 1, \dots, n$ , select  $c_{j,p}, d_{j,p}$  for all  $p \in \{1, \dots, k\}$ . If  $\xi_i = 1$  select  $t_{i,p}, t'_{i,p}$  for all  $p \in \{0, \dots, 2k(m+2) - 1\}$ . If  $\xi_i = 0$  select  $f_{i,p}, f'_{i,p}$  for all  $p \in \{0, \dots, 2k(m+2) - 1\}$ . For  $j = 1, \dots, m$ , since  $\xi$  is a truth assignment for  $f$ , at least one of the three literals of  $C_j$  is equal to 1, say  $y_j^q = 1$  for some  $q \in \{1, 2, 3\}$ . Then select  $u_{j,p}^q$  for all  $p \in \{1, \dots, 2k\}$ . Now it is a routine matter to check that the selected vertices induce a cycle  $Z$  that contains  $x, y$ , and that  $Z$  is chordless, so it is a hole. The main point is that there is no chord in  $Z$  between some subgraph  $G(C_j)$  and some subgraph  $G(z_i)$ , for that would be either an edge  $t_{i,p}u_{j,r}^q$  with  $y_j^q = z_i$  and  $\xi_i = 1$ , or, symmetrically, an edge  $f_{i,p}u_{j,r}^q$  with  $y_j^q = \bar{z}_i$  and  $\xi_i = 0$ , and in either case this would contradict the way the vertices of  $Z$  were selected.

Conversely, suppose that  $G_f(k, \alpha, \beta, \gamma, \delta, \varepsilon, \zeta)$  admits a hole  $Z$  that contains  $x, y$ .

(1) For  $i = 1, \dots, n$ ,  $Z$  contains at least  $4k + 4k(m+2)$  vertices of  $G(z_i)$ :  $4k$  of these are  $a_{i,p}, a'_{i,p}, b_{i,p}, b'_{i,p}$  where  $p \in \{1, \dots, k\}$ , and the others are either the  $t_{i,p}, t'_{i,p}$ 's or the  $f_{i,p}, f'_{i,p}$ 's where  $p \in \{0, \dots, 2k(m+2) - 1\}$ .

Let us first deal with the case  $i = 1$ . Since  $x \in Z$  has degree 2,  $Z$  contains  $a_{1,1}, \dots, a_{1,k}$  and  $a'_{1,1}, \dots, a'_{1,k}$ . Hence exactly one of  $t_{1,0}, f_{1,0}$  is in  $Z$ . Likewise exactly one of  $t'_{1,0}, f'_{1,0}$  is in  $Z$ . If  $t_{1,0}, f'_{1,0}$  are both in  $Z$  then there is a contradiction: indeed, if  $\alpha = 1$  then,  $t_{1,0}, \dots, t_{1,2k}$  and  $f'_{1,0}, \dots, f'_{1,2k}$  must all be in  $Z$ , and since  $t_{1,2k}$  sees  $f'_{1,2k}$ ,  $Z$  cannot go through  $y$ ; and if  $\alpha = 2$  the proof is similar. Similarly,  $t_{1,0}, f'_{1,0}$  cannot both be in  $Z$ . So, there exists a largest integer  $p \leq 2k(m+2) - 1$  such that either  $t_{1,0}, \dots, t_{1,p}$  and  $t'_{1,0}, \dots, t'_{1,p}$  are all in  $Z$  or  $f_{1,0}, \dots, f_{1,p}$  and  $f'_{1,0}, \dots, f'_{1,p}$  are all in  $Z$ .

We claim that  $p = 2k(m+2) - 1$ . For otherwise, some vertex  $w$  in  $\{t_{1,p}, t'_{1,p}, f_{1,p}, f'_{1,p}\}$  is incident to a red edge  $e$  of  $Z$ . If  $\alpha = 1$  then, up to a symmetry, we assume that  $t_{1,0}, \dots, t_{1,p}$  and  $t'_{1,0}, \dots, t'_{1,p}$  are all in  $Z$ . Let  $w'$  be the vertex of  $e$  that is not  $w$ . Then  $w'$  (which is either an  $f_{1,\cdot}$ , an  $f'_{1,\cdot}$  or a  $u_{j,\cdot}^q$ ) is a neighbor of both  $t_{1,p}, t'_{1,p}$ . Hence,  $Z$  cannot go through  $y$ , a contradiction. This proves our claim when  $\alpha = 1$ . If  $\alpha = 2$ , we distinguish between the following six cases.

*Case 1:*  $p = k - 1$ . Then  $e = t_{1,k-1}f'_{1,2k}$ . Clearly  $t_{1,0}, \dots, t_{1,k-1}$  must all be in  $Z$ . If  $t'_{1,0}, \dots, t'_{1,2k}$  are in  $Z$ , there is a contradiction because of  $t'_{1,2k}f'_{1,2k}$ , and if  $f'_{1,0}, \dots, f'_{1,2k}$  are in  $Z$ , there is a contradiction because of  $e$ .

*Case 2:*  $p = 2kl$  where  $1 \leq l \leq m+1$  and  $w = t'_{1,2kl}$ . Then  $e$  is  $t'_{1,2kl}f_{1,2kl+k-1}$  or  $t'_{1,2kl}f'_{1,2kl}$ . In either case,  $t_{1,2kl}, \dots, t_{1,2kl+k-1}$  are all in  $Z$ , and there is a contradiction because of the red edge  $f_{1,2kl+k-1}t_{1,2kl+k-1}$  or  $t_{1,2(l-1)k+k-1}f'_{1,2kl}$ , or when  $l = m+1$  because of  $b_{1,1}$ .

*Case 3:*  $p = 2kl$  where  $1 \leq l \leq m+1$  and  $w = f'_{1,2kl}$ . Then  $e$  is  $f'_{1,2kl}t_{1,2(l-1)k+k-1}$  or  $t'_{1,2kl}f'_{1,2kl}$ . In either case,  $f_{1,2kl}, \dots, f_{1,2kl+k-1}$  are all in  $Z$ , and there is a contradiction because of the red edge  $t_{1,2(l-1)k+k-1}f_{1,2(l-1)k+k-1}$  or  $t'_{1,2kl}f_{1,2kl+k-1}$ , or when  $l = 1$  because of  $a_{1,k}$ .

*Case 4:*  $p = 2kl + k - 1$  where  $1 \leq l \leq m$  and  $w = t_{1,2kl+k-1}$ . Then  $e$  is  $t_{1,2kl+k-1}f_{1,2kl+k-1}$ ,  $t_{1,2kl+k-1}f'_{1,2(l+1)k}$ , or  $t_{1,2kl+k-1}u_{j,k}^q$  for some  $j, q$ . In the last case, there is a contradiction since  $t'_{1,2kl+k-1} \in Z$  also sees  $u_{j,k}^q$ . For the same reason,  $t'_{1,2kl+k-1}u_{j,k}^q$  is not an edge of  $Z$  and  $t'_{1,2kl+k-1}, \dots, t'_{1,2(l+1)k}$  are

all in  $Z$ . So there is a contradiction because of the red edge  $t'_{1,2kl}f_{1,2kl+k-1}$  or  $t'_{1,2(l+1)k}f'_{1,2(l+1)k}$ .

*Case 5:*  $p = 2kl + k - 1$  where  $2 \leq l \leq m$  and  $w = f_{1,2kl+k-1}$ . Then  $e$  is  $f_{1,2kl+k-1}t_{1,2kl+k-1}$ ,  $f_{1,2kl+k-1}t'_{1,2kl}$ , or  $f_{1,2kl+k-1}u_{j,k}^q$  for some  $j, q$ . In the last case, there is a contradiction since  $f'_{1,2kl+k-1} \in Z$  also sees  $u_{j,k}^q$ . For the same reason,  $f'_{1,2kl+k-1}u_{j,k}^q$  is not an edge of  $Z$  and  $f'_{1,2kl+k-1}, \dots, f'_{1,2(l+1)k}$  are all in  $Z$ . So there is a contradiction because of the red edge  $t'_{1,2kl}f'_{1,2kl}$  or  $t_{1,2kl+k-1}f'_{1,2(l+1)k}$ .

*Case 6:*  $p = 2k(m+1) + k - 1$  and  $w = f_{1,2k(m+1)+k-1}$ . Then there is a contradiction because of the red edge  $t'_{1,2k(m+1)}f'_{1,2k(m+1)}$ . This proves our claim.

Since  $p = 2k(m+2) - 1$ ,  $b_{1,1}$  is in  $Z$ . We claim that  $b_{1,2}$  is in  $Z$ . For otherwise, the two neighbors of  $b_{1,1}$  in  $Z$  are  $t_{1,2k(m+2)-1}$  and  $f_{1,2k(m+2)-1}$ . This is a contradiction because of the red edges  $t_{1,2km+k-1}f'_{1,2k(m+1)}$ ,  $t'_{1,2k(m+1)}f_{1,2k(m+1)+k-1}$  (if  $\alpha = 2$ ) or  $t_{1,2k(m+1)}f'_{1,2k(m+1)}$ ,  $t'_{1,2k(m+1)}f_{1,2k(m+1)}$  (if  $\alpha = 1$ ). Similarly,  $b'_{1,1}, b'_{1,2}$  are in  $Z$ . So  $b_{1,1}, \dots, b_{1,k}$  and  $b'_{1,1}, \dots, b'_{1,k}$  are all in  $Z$ .

This proves (1) for  $i = 1$ . The proof for  $i = 2$  is essentially the same as for  $i = 1$ , and by induction the claim holds up to  $i = n$ . This proves (1).

(2) For  $j = 1, \dots, m$ ,  $Z$  contains  $c_{j,1}, \dots, c_{j,k}$ ,  $d_{j,1}, \dots, d_{j,k}$  and exactly one of  $\{u_{j,1}^1, \dots, u_{j,2k}^1\}$ ,  $\{u_{j,1}^2, \dots, u_{j,2k}^2\}$ ,  $\{u_{j,1}^3, \dots, u_{j,2k}^3\}$ .

Let us first deal with the case  $j = 1$ . By (1),  $b'_{n,k}$  is in  $Z$  and so  $c_{1,1}, \dots, c_{1,k}$  are all in  $Z$ . Consequently exactly one of  $u_{1,1}^1, u_{1,1}^2, u_{1,1}^3$  is in  $Z$ , say  $u_{1,1}^1$  up to a symmetry. Note that the neighbour of  $u_{1,1}^1$  in  $Z \setminus c_1$  cannot be a vertex among  $u_{1,1}^2, u_{1,1}^3$  for this would imply that  $Z$  contains a triangle. Hence  $u_{1,2}^1, \dots, u_{1,k}^1$  are all in  $Z$ . The neighbour of  $u_{1,k}^1$  in  $Z \setminus u_{1,k-1}^1$  cannot be in some  $G(z_i)$  ( $1 \leq i \leq n$ ). Else, up to a symmetry we assume that this neighbor is  $t_{1,p}$ ,  $p \in \{0, \dots, 2k(m+2) - 1\}$ . If  $t_{1,p} \in Z$ , there is a contradiction because then  $t'_{1,p}$  is also in  $Z$  by (1) and  $t'_{1,p}$  would be a third neighbour of  $u_{1,k}^1$  in  $Z$ . If  $t_{1,p} \notin Z$ , there is a contradiction because then the neighbor of  $t_{1,p}$  in  $Z \setminus u_{1,k}^1$  must be  $t_{1,p+1}$  (or symmetrically  $t_{1,p-1}$ ) for otherwise  $Z$  contains a triangle. So,  $t_{1,p+1}, t_{1,p+2}, \dots$  must be in  $Z$ , till reaching a vertex having a neighbor  $f_{1,p'}$  or  $f'_{1,p'}$  in  $Z$  (whatever  $\alpha$ ). Thus the neighbour of  $u_{1,k}^1$  in  $Z \setminus u_{1,k-1}^1$  is  $u_{1,k+1}^1$ . Similarly, we prove that  $u_{1,k+2}, \dots, u_{1,2k}$  are in  $Z$ , that  $d_{1,1}, \dots, d_{1,k}$  are in  $Z$ , and so the claim holds for  $j = 1$ . The proof of the claim for  $j = 2$  is essentially the same as for  $j = 1$ , and by induction the claim holds up to  $j = m$ . This proves (2).

Together with  $x, y$ , the vertices of  $Z$  found in (1) and (2) actually induce a cycle. So, since  $Z$  is a hole, they are the members of  $Z$  and we can replace “at least” by “exactly” in (1). We can now make a Boolean vector  $\xi$  as follows. For  $i = 1, \dots, n$ , if  $Z$  contains  $t_{i,0}, t'_{i,0}$  set  $\xi_i = 1$ ; if  $Z$  contains  $f_{i,0}, f'_{i,0}$  set  $\xi_i = 0$ . By (1) this is consistent. Consider any clause  $C_j$  ( $1 \leq j \leq m$ ). By (2) and up to symmetry we may assume that  $u_{j,k}^1$  is in  $Z$ . If  $y_j^1 = z_i$  for some  $i \in \{1, \dots, n\}$ , then the construction of  $G$  implies that  $f_{i,2kj+k-1}, f'_{i,2kj+k-1}$  are not in  $Z$ , so  $t_{i,2kj+k-1}, t'_{i,2kj+k-1}$  are in  $Z$ , so  $\xi_i = 1$ , so clause  $C_j$  is satisfied by  $x_i$ . If  $y_j^1 = \bar{z}_i$  for some  $i \in \{1, \dots, n\}$ , then the construction of  $G_f$  implies that

$t_{i,2kj+k-1}, t'_{i,2kj+k-1}$  are not in  $Z$ , so  $f_{i,2kj+k-1}, f'_{i,2kj+k-1}$  are in  $Z$ , so  $\xi_i = 0$ , so clause  $C_j$  is satisfied by  $\bar{z}_i$ . Thus  $\xi$  is a truth assignment for  $f$ .  $\square$

**Theorem 2.3** *Let  $k \geq 5$  be an integer.*

*Then  $\Gamma_{\{C_3, \dots, C_k, K_{1,6}\}}$  and  $\Gamma_{\{I_1, \dots, I_k, C_5, \dots, C_k, K_{1,4}\}}$  are NP-complete.*

PROOF — It is a routine matter to check that the graph  $G_f(k, 2, 0, 0, 0, 0, 0)$  contains no  $C_l$  ( $3 \leq l \leq k$ ) and no  $K_{1,6}$  (in fact it has no vertex of degree at least 6). So Lemma 2.2 implies that  $\Gamma_{\{C_3, \dots, C_k, K_{1,6}\}}$  is NP-complete.

It is a routine matter to check that the graph  $G_f(k, 1, 1, 1, 3, 1, 1)$  contains no  $K_{1,4}$ , no  $C_l$  ( $5 \leq l \leq k$ ) and no  $I_{l'}$  ( $3 \leq l' \leq k$ ). So Lemma 2.2 implies that  $\Gamma_{\{K_{1,4}, C_5, \dots, C_k, I_3, \dots, I_k\}}$  is NP-complete.  $\square$

## Complexity of $\Gamma_{\{H\}}$ when $H$ is a connected graph

**Theorem 2.4** *Let  $H$  be a connected graph. Then either :*

- *$H$  is a path or a subdivided claw and  $\Gamma_{\{H\}}$  is polynomial.*
- *$H$  contains one of  $K_{1,4}$ ,  $I_k$  for some  $k \geq 1$ , or  $C_l$  for some  $l \geq 3$  as an induced subgraph and  $\Gamma_{\{H\}}$  is NP-complete.*

PROOF — If  $H$  contains one of  $K_{1,4}$ ,  $I_k$  for some  $k \geq 1$ , or  $C_l$  for some  $l \geq 3$  as an induced subgraph then  $\Gamma_{\{H\}}$  is NP-complete by Theorem 2.3. Else,  $H$  is a tree since it contains no  $C_l$ ,  $l \geq 3$ . If  $H$  has no vertex of degree at least 3, then  $H$  is a path and  $\Gamma_{\{H\}}$  is polynomial by Theorem 2.1. If  $H$  has a single vertex of degree at least 3, then this vertex has degree 3 because  $H$  contains no  $K_{1,4}$ . So,  $H$  is a subdivided claw and  $\Gamma_{\{H\}}$  is polynomial by Theorem 2.1. If  $H$  has at least two vertices of degree at least 3 then  $H$  contains an  $I_l$ , where  $l$  is the length of the unique path of  $H$  joining these two vertices. This is a contradiction.  $\square$

Interestingly, a similar theorem was proved by Alekseev:

**Theorem 2.5 (Alekseev, [1])** *Let  $H$  be a connected graph that is not a path nor a subdivided claw. Then the problem of finding a maximum stable set in  $H$ -free graphs is NP-hard.*

But the complexity of the maximum stable set problem is not known in general for  $H$ -free graphs when  $H$  is a path or a subdivided claw. See [7] for a survey.

## NP-complete cases (bounded degree)

Here, we will show that  $\Gamma^d$  is NP-complete when  $d \geq 3$  and polynomial when  $d = 2$ . If  $\mathcal{S}$  is any finite list of cycles  $C_{k_1}, C_{k_2}, \dots, C_{k_m}$ , then we will also show that  $\Gamma_{\mathcal{S}}^3$  is NP-complete as long as  $C_6 \notin \mathcal{S}$ .

Let  $f$  be an instance of 3-SATISFIABILITY, consisting of  $m$  clauses  $C_1, \dots, C_m$  on  $n$  variables  $z_1, \dots, z_n$ . For each clause  $C_j$  ( $j = 1, \dots, m$ ), with  $C_j = y_{3i-2} \vee y_{3i-1} \vee y_{3i}$ , then  $y_i$  ( $i = 1, \dots, 3m$ ) is a literal from  $\{z_1, \dots, z_n, \bar{z}_1, \dots, \bar{z}_n\}$ .

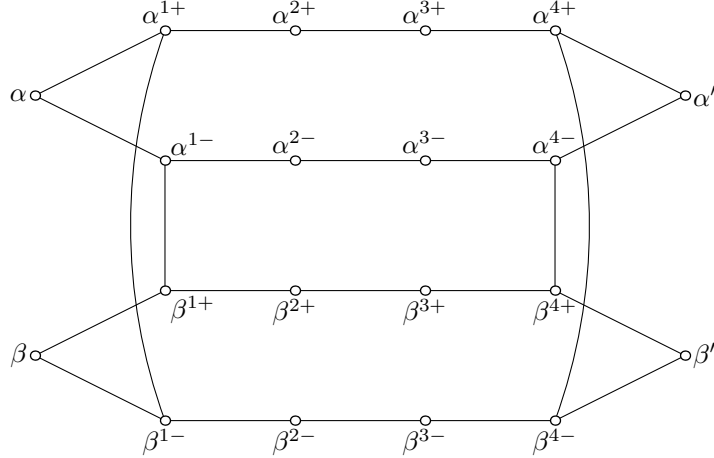

Figure 11: The graph  $G(y_j)$

Let us build a graph  $G_f$  with two specialized vertices  $x$  and  $y$  of degree 2 such that  $\Delta(G_f) = 3$ . There will be a hole containing  $x$  and  $y$  in  $G_f$  if and only if there exists a truth assignment for  $f$ .

For each literal  $y_j$  ( $j = 1, \dots, 3m$ ), prepare a graph  $G(y_j)$  on 20 vertices  $\alpha, \alpha', \alpha^{1+}, \dots, \alpha^{4+}, \alpha^{1-}, \dots, \alpha^{4-}, \beta, \beta', \beta^{1+}, \dots, \beta^{4+}, \beta^{1-}, \dots, \beta^{4-}$ . (We drop the subscript  $j$  in the labels of the vertices for clarity).

For  $i = 1, 2, 3$  add the edges  $\alpha^{i+}\alpha^{(i+1)+}, \beta^{i+}\beta^{(i+1)+}, \alpha^{i-}\alpha^{(i+1)-}, \beta^{i-}\beta^{(i+1)-}$ . Also add the edges  $\alpha^{1+}\beta^{1-}, \alpha^{1-}\beta^{1+}, \alpha^{4+}\beta^{4-}, \alpha^{4-}\beta^{4+}, \alpha\alpha^{1+}, \alpha\alpha^{1-}, \alpha^{4+}\alpha', \alpha^{4-}\alpha', \beta\beta^{1+}, \beta\beta^{1-}, \beta^{4+}\beta', \beta^{4-}\beta'$ .

For each clause  $C_j$  ( $j = 1, \dots, m$ ), prepare a graph  $G(C_j)$  with 10 vertices  $c^{1+}, c^{2+}, c^{3+}, c^{1-}, c^{2-}, c^{3-}, c^{0+}, c^{12+}, c^{0-}, c^{12-}$ . (We drop the subscript  $j$  in the labels of the vertices for clarity).

Add the edges  $c^{12+}c^{1+}, c^{12+}c^{2+}, c^{12-}c^{1-}, c^{12-}c^{2-}, c^{0+}c^{12+}, c^{0+}c^{3+}, c^{0-}c^{12-}, c^{0-}c^{3-}$ .

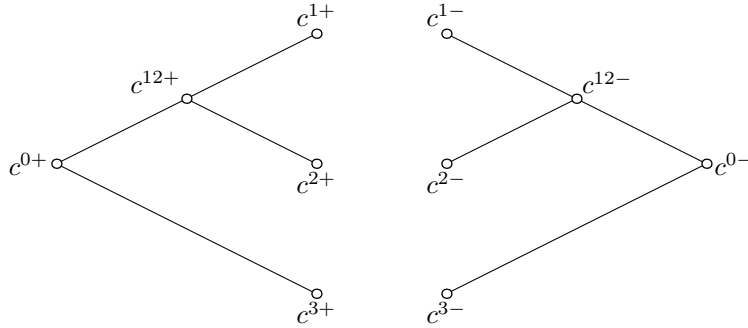

Figure 12: The graph  $G(C_j)$

For each variable  $z_i$  ( $i = 1, \dots, n$ ), prepare a graph  $G(z_i)$  with  $2z_i^- + 2z_i^+$  vertices, where  $z_i^-$  is the number of times  $\bar{z}_i$  appears in clauses  $C_1, \dots, C_m$  and  $z_i^+$  is the number of times  $z_i$  appears in clauses  $C_1, \dots, C_m$ .

Let  $G(z_i)$  consist of two internally disjoint paths  $P_i^+$  and  $P_i^-$  with common endpoints  $d_i^+$  and  $d_i^-$  and lengths  $1 + 2z_i^-$  and  $1 + 2z_i^+$  respectively. Label the vertices of  $P_i^+$  as  $d_i^+, p_{i,1}^+, \dots, p_{i,2f_i}^+, d_i^-$  and label the vertices of  $P_i^-$  as  $d_i^+, p_{i,1}^-, \dots, p_{i,2g_i}^-, d_i^-$ .

The final graph  $G_f$  (see figure 2) will be constructed from the disjoint union of all the graphs  $G(y_j)$ ,  $G(C_i)$ , and  $G(x_i)$  with the following modifications:

- For  $j = 1, \dots, 3m - 1$ , add the edges  $\alpha'_j \alpha_{j+1}$  and  $\beta'_j \beta_{j+1}$ . This creates one connected chain of the graphs  $G(y_j)$ .
- For  $j = 1, \dots, m - 1$ , add the edge  $c_j^{0-} c_{j+1}^{0+}$ . This creates one connected chain of the graphs  $G(C_j)$ .
- For  $i = 1, \dots, n - 1$ , add the edge  $d_i^- d_{i+1}^+$ . This creates one connected chain of the graphs  $G(x_i)$ .
- For  $i = 1, \dots, n$ , let  $y_{n_1}, \dots, y_{n_{z_i^-}}$  be the occurrences of  $\bar{x}_i$  over all literals.  
For  $j = 1, \dots, z_i^-$ , delete the edge  $p_{i,2j-1}^+ p_{i,2j}^+$  and add the four edges  $p_{i,2j-1}^+ \alpha_{n_j}^{2+}, p_{i,2j-1}^+ \beta_{n_j}^{2+}, p_{i,2j}^+ \alpha_{n_j}^{3+}, p_{i,2j}^+ \beta_{n_j}^{3+}$ .
- For  $i = 1, \dots, n$ , let  $y_{n_1}, \dots, y_{n_{z_i^+}}$  be the occurrences of  $x_i$  over all literals.  
For  $j = 1, 2, \dots, z_i^+$ , delete the edge  $p_{i,2j-1}^- p_{i,2j}^-$  and add the four edges  $p_{i,2j-1}^- \alpha_{n_j}^{2+}, p_{i,2j-1}^- \beta_{n_j}^{2+}, p_{i,2j}^- \alpha_{n_j}^{3+}, p_{i,2j}^- \beta_{n_j}^{3+}$ .
- For  $i = 1, \dots, m$  and  $j = 1, 2, 3$ , add the edges  $\alpha_{3(i-1)+j}^{2-} c_i^{j+}, \alpha_{3(i-1)+j}^{3-} c_i^{j-}, \beta_{3(i-1)+j}^{2-} c_i^{j+}, \beta_{3(i-1)+j}^{3-} c_i^{j-}$ .
- Add the edges  $\alpha'_{3m} d_1^+$  and  $\beta'_{3m} c_1^{0+}$
- Add the vertex  $x$  and add the edges  $x\alpha_1$  and  $x\beta_1$ .
- Add the vertex  $y$  and add the edges  $yc_m^{0-}$  and  $yd_n^-$ .

It is easy to verify that  $\Delta(G_f) = 3$ , that  $G_f$  is polynomial (actually linear) in the size  $n + m$  of  $f$ , and that  $x, y$  are non-adjacent and both have degree two.

**Lemma 2.6**  *$f$  admits a truth assignment if and only if  $G_f$  contains a hole passing through  $x$  and  $y$ .*

PROOF — First assume that  $f$  admits a truth assignment  $\xi \in \{0, 1\}^n$ . We will pick a set of vertices that induce a hole containing  $x$  and  $y$ .

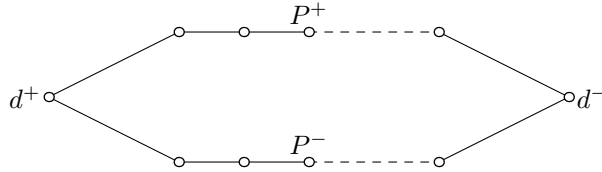

Figure 13: The graph  $G(z_i)$

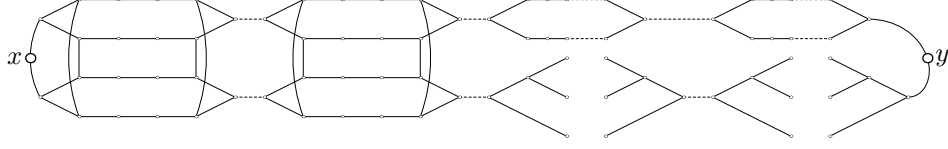

Figure 14: The final graph  $G_f$

1. Pick vertices  $x$  and  $y$ .
2. For  $i = 1, \dots, 3m$ , pick the vertices  $\alpha_i, \alpha'_i, \beta_i, \beta'_i$ .
3. For  $i = 1, \dots, 3m$ , if  $y_i$  is satisfied by  $\xi$ , then pick the vertices  $\alpha_i^{1+}, \alpha_i^{2+}, \alpha_i^{3+}, \alpha_i^{4+}, \beta_i^{1+}, \beta_i^{2+}, \beta_i^{3+}, \beta_i^{4+}$ , and  $\beta_i^{4+}$ . Otherwise, pick the vertices  $\alpha_i^{1-}, \alpha_i^{2-}, \alpha_i^{3-}, \alpha_i^{4-}, \beta_i^{1-}, \beta_i^{2-}, \beta_i^{3-}, \beta_i^{4-}$ .
4. For  $i = 1, \dots, n$ , if  $\xi_i = 1$ , then pick all the vertices of the path  $P_i^+$  and all the neighbors of the vertices in  $P_i^+$  of the form  $\alpha_k^{2+}$  or  $\alpha_k^{3+}$  for any  $k$ .
5. For  $i = 1, \dots, n$ , if  $\xi_i = 0$ , then pick all the vertices of the path  $P_i^-$  and all the neighbors of the vertices in  $P_i^-$  of the form  $\alpha_k^{2+}$  or  $\alpha_k^{3+}$  for any  $k$ .
6. For  $i = 1, \dots, m$ , pick the vertices  $c_i^{0+}$  and  $c_i^{0-}$ . Choose any  $j \in \{3i - 2, 3i - 1, 3i\}$  such that  $\xi$  satisfies  $y_j$ . Pick vertices  $\alpha_j^{2-}$ , and  $\alpha_j^{3-}$ . If  $j = 3i - 2$ , then pick the vertices  $c_i^{12+}, c_i^{1+}, c_i^{1-}, c_i^{12-}$ . If  $j = 3i - 1$ , then pick the vertices  $c_i^{12+}, c_i^{2+}, c_i^{2-}, c_i^{12-}$ . If  $j = 3i$ , then pick the vertices  $c_i^{3+}$  and  $c_i^{3-}$ .

It suffices to show that the chosen vertices induce a hole containing  $x$  and  $y$ . The only potential problem is that for some  $k$ , one of the vertices  $\alpha_k^{2+}, \alpha_k^{3+}, \alpha_k^{2-}$ , or  $\alpha_k^{3-}$  was chosen multiple times. If  $\alpha_k^{2+}$  and  $\alpha_k^{3+}$  were picked in Step 3, then  $y_k$  is satisfied by  $\xi$ . Therefore,  $\alpha_k^{2+}$  and  $\alpha_k^{3+}$  were not chosen in Step 4 or Step 5. Similarly, if  $\alpha_k^{2-}$  and  $\alpha_k^{3-}$  were picked in Step 6, then  $y_k$  is satisfied by  $\xi$  and  $\alpha_k^{2-}$  and  $\alpha_k^{3-}$  were not picked in Step 3. Thus, the chosen vertices induce a hole in  $G$  containing vertices  $x$  and  $y$ .

Now assume  $G_f$  contains a hole  $H$  passing through  $x$  and  $y$ . The hole  $H$  must contain  $\alpha_1$  and  $\beta_1$  since they are the only two neighbors of  $x$ . Next, either both  $\alpha_1^{1+}$  and  $\beta_1^{1+}$  are in  $H$ , or both  $\alpha_1^{1-}$  and  $\beta_1^{1-}$  are in  $H$ .

Without loss of generality, let  $\alpha_1^{1+}$  and  $\beta_1^{1+}$  be in  $H$  (the same reasoning that follows will hold true for the other case). Since  $\beta_1^{1-}$  and  $\alpha_1^{1-}$  are both neighbors of two members in  $H$ , they cannot be in  $H$ . Thus,  $\alpha_1^{2+}$  and  $\beta_1^{2+}$  must be in  $H$ . Since  $\alpha_1^{2+}$  and  $\beta_1^{2+}$  have the same neighbor outside  $G(y_1)$ , it follows that  $H$  must contain  $\alpha_1^{3+}$  and  $\beta_1^{3+}$ . Also,  $H$  must contain  $\alpha_1^{4+}$  and  $\beta_1^{4+}$ . Suppose that  $\alpha_1^{4-}$  and  $\beta_1^{4-}$  are in  $H$ . Because  $\alpha_1^{i-}$  has the same neighbor as  $\beta_1^{i-}$  outside  $G(y_1)$  for  $i = 2, 3$ , it follows that  $H$  must contain  $\alpha_1^{3-}, \alpha_1^{2-}$ , and  $\alpha_1^{1-}$ . But then  $H$  is not a hole containing  $b$ , a contradiction. Therefore,  $\alpha_1^{4-}$  and  $\beta_1^{4-}$  cannot both be in  $H$ , so  $H$  must contain  $\alpha'_1, \beta'_1, \alpha_2$ , and  $\beta_2$ .

By induction, we see for  $i = 1, 2, \dots, 3m$  that  $H$  must contain  $\alpha_i, \alpha'_i, \beta_i, \beta'_i$ . Also, for each  $i$ , either  $H$  contains  $\alpha_i^{1+}, \alpha_i^{2+}, \alpha_i^{3+}, \alpha_i^{4+}, \beta_i^{1+}, \beta_i^{2+}, \beta_i^{3+}, \beta_i^{4+}$  or  $H$  contains  $\alpha_i^{1-}, \alpha_i^{2-}, \alpha_i^{3-}, \alpha_i^{4-}, \beta_i^{1-}, \beta_i^{2-}, \beta_i^{3-}, \beta_i^{4-}$ .

As a result,  $H$  must also contain  $d_1^+$  and  $c_1^{0+}$ . By symmetry, we may assume  $H$  contains  $p_{1,1}^+$  and  $\alpha_k^{2+}$  for some  $k$ . Since  $\alpha_k^{1+}$  is adjacent to two vertices

in  $H$ ,  $H$  must contain  $\alpha_k^{3+}$ . Similarly,  $H$  cannot contain  $\alpha_k^{4+}$ , so  $H$  contains  $p_{1,2}^+$  and  $p_{1,3}^+$ . By induction, we see that  $H$  contains  $p_{1,i}^+$  for  $i = 1, 2, \dots, z_i^+$  and  $d_1^-$ . If  $H$  contains  $p_{1,z_i}^-$ , then  $H$  must contain  $p_{1,i}^-$  for  $i = z_i^-, \dots, 1$ , a contradiction. Thus,  $H$  must contain  $d_2^+$ . By induction, for  $i = 1, 2, \dots, n$ , we see that  $H$  contains all the vertices of the path  $P_i^+$  or  $P_i^-$  and by symmetry, we may assume  $H$  contains all the neighbors of the vertices in  $P_i^+$  or  $P_i^-$  of the form  $\alpha_k^{2+}$  or  $\alpha_k^{3+}$  for any  $k$ .

Similarly, for  $i = 1, 2, \dots, m$ , it follows that  $H$  must contain  $c_i^{0+}$  and  $c_i^{0-}$ . Also,  $H$  contains one of the following:

- $c_i^{12+}, c_i^{1+}, c_i^{1-}, c_i^{12-}$  and either  $\alpha_j^{2-}$  and  $\alpha_j^{3-}$  or  $\beta_j^{2-}$  and  $\beta_j^{3-}$  (where  $\alpha_j^{2-}$  is adjacent to  $c_i^{1+}$ ).
- $c_i^{12+}, c_i^{2+}, c_i^{2-}, c_i^{12-}$  and either  $\alpha_j^{2-}$  and  $\alpha_j^{3-}$  or  $\beta_j^{2-}$  and  $\beta_j^{3-}$  (where  $\alpha_j^{2-}$  is adjacent to  $c_i^{2+}$ ).
- $c_i^{3+}$  and  $c_i^{3-}$  and either  $\alpha_j^{2-}$  and  $\alpha_j^{3-}$  or  $\beta_j^{2-}$  and  $\beta_j^{3-}$  (where  $\alpha_j^{2-}$  is adjacent to  $c_i^{3+}$ ).

We can recover the satisfying assignment  $\xi$  as follows. For  $i = 1, 2, \dots, n$ , set  $\xi_i = 1$  if the vertices of  $P_i^+$  are in  $H$  and set  $\xi_i = 0$  if the vertices of  $P_i^-$  are in  $H$ . By construction, it is easy to verify that at least one literal in every clause is satisfied, so  $\xi$  is indeed a satisfying assignment.  $\square$

**Theorem 2.7** *The following statements hold:*

- For any  $d \in \mathbb{Z}$  with  $d \geq 2$ , the problem  $\Gamma^d$  is NP-complete when  $d \geq 3$  and polynomial when  $d = 2$ .
- If  $\mathcal{H}$  is any finite list of cycles  $C_{k_1}, C_{k_2}, \dots, C_{k_m}$  such that  $C_6 \notin \mathcal{H}$ , then  $\Gamma_{\mathcal{H}}^3$  is NP-complete.

PROOF — In the above reduction,  $\Delta(G_f) = 3$  so  $\Gamma^d$  is NP-complete for  $d \geq 3$ . When  $d = 2$ , there is a simple  $O(n)$  algorithm. Any hole containing  $x$  and  $y$  must be a component of  $G$  so pick the vertex  $x$  and consider the component  $C$  of  $G$  that contains  $x$ . It takes  $O(n)$  time to verify whether  $C$  is a hole containing  $x$  and  $y$  or not.

To show the second statement, let  $K$  be the length of the longest cycle in  $\mathcal{H}$ . In the above reduction, do the following modifications.

- For  $i = 1, 2, 3$  and  $j = 1, 2, \dots, 3m$ , replace the edges  $\alpha_j^{i+} \alpha_j^{(i+1)+}$ ,  $\alpha_j^{i-} \alpha_j^{(i+1)-}$ ,  $\beta_j^{i+} \beta_j^{(i+1)+}$ , and  $\beta_j^{i-} \beta_j^{(i+1)-}$  by paths of length  $K$ .
- For  $j = 1, 2, \dots, 3m - 1$ , replace the edges  $\alpha'_j \alpha_{j+1}$  and  $\beta'_j \beta_{j+1}$  by paths of length  $K$ .
- Replace the edges  $x\alpha_1$  and  $x\beta_1$  by paths of length  $K$ .

This new reduction is polynomial in  $n$  and  $m$  and is  $\mathcal{H}$ -free. The proof of Lemma 2.6 still holds for this new reduction so therefore,  $\Gamma_{\mathcal{H}}^3$  is NP-complete.  $\square$

### 3 $\Pi_B$ for some special s-graphs

#### 3.1 Holes with pending edges and trees

Here, we study  $\Pi_{B_4}, \dots, \Pi_{B_7}$  where  $B_4, \dots, B_7$  are the s-graphs depicted on Figure 3. Our motivation is simply to give a striking example and to point out that surprisingly, pending edges of s-graphs matter and that even an s-graph with no cycle can lead to NP-complete problems.

**Theorem 3.1** *There is an  $O(n^{13})$ -time algorithm for  $\Pi_{B_4}$  but  $\Pi_{B_5}$  is NP-complete.*

PROOF — A realisation of  $B_4$  has exactly one vertex of degree 3 and one vertex of degree 4. Let us say that the realisation  $H$  is *short* if the distance between these two vertices in  $H$  is at most 3. Detecting short realisations of  $B_4$  can be done in time  $n^9$  as follows: for every 6-tuple  $F = (a, b, x_1, x_2, x_3, x_4)$  such that  $G[F]$  has edge-set  $\{x_1a, ax_2, x_2b, bx_3, bx_4\}$  and for every 7-tuple  $F = (a, b, x_1, x_2, x_3, x_4, x_5)$  such that  $G[F]$  has edge-set  $\{x_1a, ax_2, x_2x_3, x_3b, bx_4, bx_5\}$ , delete  $x_1, \dots, x_5$  and their neighbors except  $a, b$ . In the resulting graph, check whether  $a$  and  $b$  are in the same component. The answer is YES for at least one 7-or-6-tuple if and only if  $G$  contains at least one short realisation of  $B_4$ .

Here is an algorithm for  $\Pi_{B_4}$ , assuming that the entry graph  $G$  has no short realisation of  $B_4$ . For every 9-tuple  $F = (a, b, c, x_1, \dots, x_6)$  such that  $G[F]$  has edge-set  $\{x_1a, bx_2, x_2x_3, x_3x_4, cx_5, x_5x_3, x_3x_6\}$  delete  $x_1, \dots, x_6$  and their neighbors except  $a, b, c$ . In the resulting graph, run three-in-a-tree for  $a, b, c$ . It is easily checked that the answer is YES for some 7-tuple if and only if  $G$  contains a realisation of  $B_4$ .

Let us prove that  $\Pi_{B_5}$  is NP-complete by a reduction of  $\Gamma^3$  to  $\Pi_{B_5}$ . Since by Theorem 2.7,  $\Gamma^3$  is NP-complete, this will complete the proof. Let  $(G, x, y)$  an instance of  $\Gamma^3$ . Prepare a new graph  $G'$ : add four vertices  $x', x'', y', y''$  to  $G$  and add four edges  $xx', xx'', yy', yy''$ . Since  $\Delta(G) \leq 3$ , it is easily seen that  $G$  contain a hole passing through  $x, y$  if and only if  $G'$  contains a realisation of  $B_5$ .  $\square$

The proof of the theorem below is omitted since it is similar to the proof of Theorem 3.1.

**Theorem 3.2** *There is an  $O(n^{14})$ -time algorithm for  $\Pi_{B_6}$  but  $\Pi_{B_7}$  is NP-complete.*

#### 3.2 Induced subdivisions of $K_5$

Here, we study the problem of deciding whether a graph contain an induced subdivision of  $K_5$ . More precisely, we put :  $sK_5 = (\{a, b, c, d, e\}, \emptyset, (\{a, b, c, d, e\}))$ .

**Theorem 3.3**  *$\Pi_{sK_5}$  is NP-complete.*

PROOF — We consider an instance  $(G, x, y)$  of  $\Gamma^3$ . Let us denote by  $x', x''$  the two neighbors of  $x$  and by  $y', y''$  the two neighbors of  $y$ .

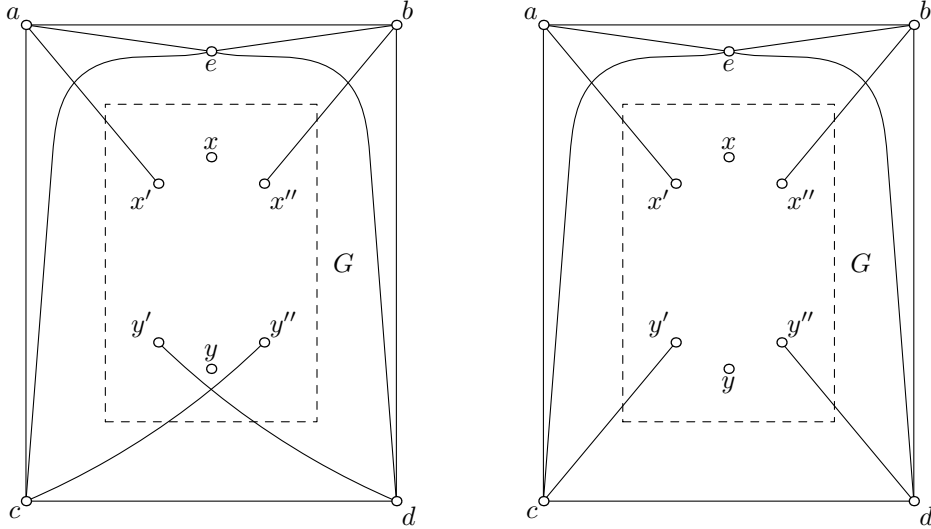

Figure 15: Graphs  $G'$  and  $G''$

Let us build a graph  $G'$  by adding five vertices  $a, b, c, d, e$ . We add the edges  $ab, bd, dc, ca, ea, eb, ec, ed, ax', bx'', cy'', dy'$ . We delete the edges  $xx', xx'', yy', yy''$ . We define a very similar graph  $G''$ , the only change being that we do not add edges  $cy'', dy'$  but edges  $cy', dy''$  instead. See figure 15.

Now in  $G'$  (and similarly  $G''$ ) every vertex has degree at most 3, except for  $a, b, c, d, e$ . We claim that  $G$  contains a hole going through  $x$  and  $y$  if and only if at least one of  $G', G''$  contains an induced subdivision of  $K_5$ . Indeed, if  $G$  contains a hole passing through  $x, x', y', y, y'', x''$  in that order then  $G'$  obviously contains an induced subdivision of  $K_5$ , and the hole passes in order through  $x, x', y'', y, y', x''$  then  $G''$  contains such a subgraph. Conversely, if  $G'$  (or symmetrically  $G''$ ) contains an induced subdivision of  $K_5$  then  $a, b, c, d, e$  must be the vertices of the underlying  $K_5$ , because they are the only vertices with degree at least 4. Hence there is a path from  $x'$  to  $y'$  in  $G \setminus \{x, y\}$  and a path from  $x''$  to  $y''$  in  $G \setminus \{x, y\}$ , and consequently a hole going through  $x, y$  in  $G$ .  $\square$

### 3.3 $\Pi_B$ for small $B$ 's

Here, we survey the complexity  $\Pi_B$  when  $B$  has at most four vertices. By the remarks in the introduction, if  $|V| \leq 3$  then  $\Pi_{(V,D,F)}$  is polynomial. Up to symmetries, we are left with twelve s-graphs on four vertices.

For the following two s-graphs, there is a polynomial algorithm using three-in-a-tree:



The next two s-graphs yield an NP-complete problem:

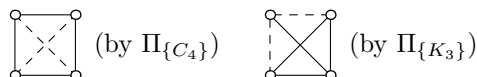

For the remaining eight ones, we do not know the answer:

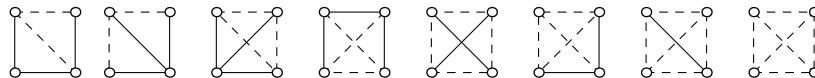

As a conclusion, we would like to point out that every detection problem associated to an s-graph for which a polynomial time algorithm is known can be solved by using three-in-a-tree or by some easy brute-force enumeration.

## References

- [1] V.E. Alekseev. On the local restrictions effect on the complexity of finding the graph independence number. *Combinatorial-algebraic methods in applied mathematics*, 132:3–13, 1983. Gorky University Press, Gorky, in Russian.
- [2] N. Alon, R. Yuster, and U. Zwick. Finding and counting given length cycles. In *Proceedings of the 2nd European Symposium on Algorithms. Utrecht, The Netherlands*, pages 354–364, 1994.
- [3] D. Bienstock. On the complexity of testing for odd holes and induced odd paths. *Discrete Math.*, 90:85–92, 1991. See also Corrigendum by B. Reed, *Discrete Math.*, 102, (1992), p. 109.
- [4] M. Chudnovsky and P. Seymour. The three-in-a-tree problem. Manuscript.
- [5] M. Chudnovsky, G. Cornuéjols, X. Liu, P. Seymour, and K. Vušković. Recognizing Berge graphs. *Combinatorica*, 25:143–186, 2005.
- [6] M.R. Garey and D.S. Johnson. *Computer and Intractability : A Guide to the Theory of NP-completeness*. W.H. Freeman, San Fransisco, 1979.
- [7] A. Hertz and V. V. Lozin. The maximum independent set problem and augmenting graphs. Manuscript.
- [8] F. Maffray and N. Trotignon. Algorithms for perfectly contractile graphs. *SIAM Jour. of Discrete Math.*, 19(3):553–574, 2005.
- [9] F. Maffray, N. Trotignon, and K. Vušković. Algorithms for square- $3PC(\cdot, \cdot)$ -free Berge graphs. *SIAM Journal on Discrete Mathematics*. To appear.
- [10] R.E. Tarjan and M. Yannakakis. Simple linear-time algorithms to test chordality of graphs, test acyclicity of hypergraphs, and selectively reduce acyclic hypergraphs. *SIAM Journal on Computing*, 13:566–579, 1984.